

There must be another way!

The common mistakes are...

I've spotted a pattern...

Have we tried...

I SEE REASONING - UKS2

TASKS FOR ENRICHING MATHEMATICAL TALK

This picture shows...

So that's why...

It's simpler if we...

I've never noticed that before!

I've spotted a pattern...

It's possible if...

What's different about...



by **GARETH METCALFE**

Instant digital download
in PDF format

I SEE REASONING – UKS2

Contents

[Introduction](#)

[Place value](#)

[Place value – decimals](#)

[Place value – negative numbers](#)

[Place value – rounding](#)

[Addition and subtraction](#)

[Multiplication](#)

[Division](#)

[Fractions](#)

[Fractions \$+\$ \$-\$ \$\times\$ \$\div\$](#)

[Ratio and proportion](#)

[Algebra](#)

[Measures](#)

[Measures – volume](#)

[Measures – area and perimeter](#)

[Geometry – shape](#)

[Geometry – angle](#)

[Geometry – coordinates](#)

[Statistics](#)

[Statistics – average](#)

[Answers](#)

I SEE REASONING – UKS2

Tasks for enriching mathematical talk

Introduction

I See Reasoning – UKS2 is written to provide rich, open contexts for mathematical discussion and enquiry.

Children apply their current understanding to solve '***I know... so...***' questions. They discuss key concepts to respond to '***Rank by difficulty***' tasks. Friends work systematically to find all possible solutions for the '***How many ways?***' challenges.

The resource is comprised of 176 varied tasks, linked to all different areas of the upper KS2 mathematics curriculum. These activities correspond to US grades 4-5 and Australia year 5-6 objectives. Screenshots of tasks can be used within presentations or printed and given to children.

I hope that ***I See Reasoning*** enriches the maths learning in your classroom!

Gareth Metcalfe

For use by the purchasing institution only. Copyright ***I See Maths Ltd***. Circulation is prohibited.

True or false?

Three thousand and
two-thousand

2 ten-thousands
and 120 hundreds

32 000

32 hundreds

3 200 tens

Rank by difficulty

Write in numbers:

Thirty-thousand five-hundred

Thirty-five thousand

Thirty-thousand and fifty

Spot the pattern

Write in words:

604 _____

6 040 _____

60 400 _____

604 000 _____

Spot the pattern

Write in words:

7 005 _____

70 050 _____

700 500 _____

7 005 000 _____

Number lines

Show the position of **8 000** on each number line.



Number lines

Show the position of **70 000** on each number line.



Different ways

What could the start and end numbers be?

683 000

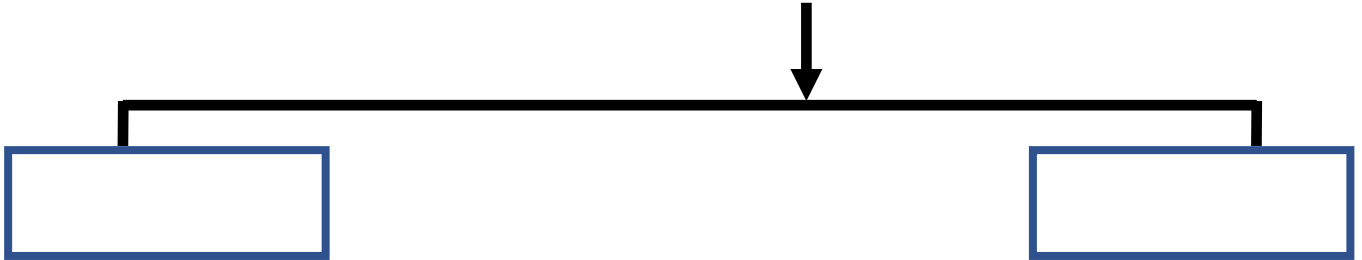

Different ways

What could the start and end numbers be?

4 620

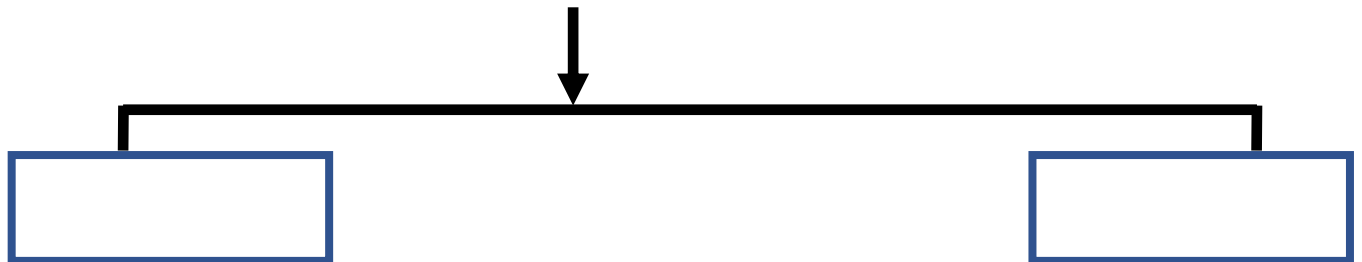

Estimate

Estimate the position of the arrow.

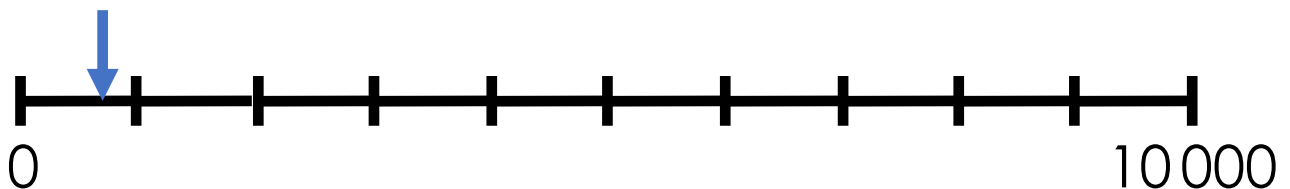

Investigate



The sum of the digits for a 3-digit number is larger than the sum of the digits for a 2-digit number.

Make the two numbers using digits 0-9 (no repeats). Minimise the difference between the numbers.

Investigate



The sum of the digits for a 4-digit number is larger than the sum of the digits for a 3-digit number.

Make the two numbers using digits 0-9 (no repeats). Minimise the difference between the numbers.

True or false?

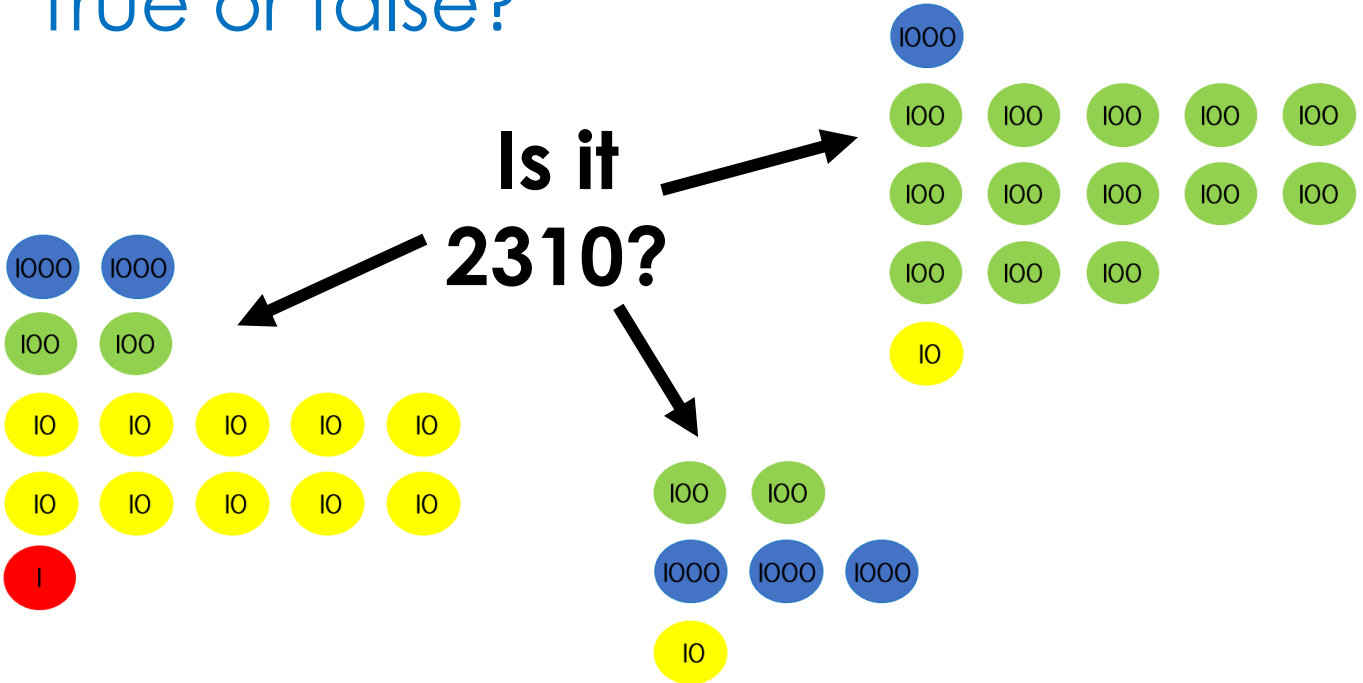

Explain

Put the following in order from fewest to most:

A – seconds in January

B – people at an English Premier League football match

C – people living in Wales

D – days in a decade

Number lines

Show the position of **0.43** on each number line.



Number lines

Show the position of **0.06** on each number line.



How many ways?

You have a pile of 1 coins and a pile of 0.1 coins.

Make 2.4

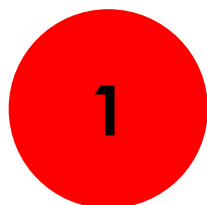

Level 1: I can find a way

Level 2: I can find different ways

Level 3: I know how many ways there are

How many ways?

You have a pile of 0.1 coins and a pile of 0.01 coins.

Make 0.32



Level 1: I can find a way

Level 2: I can find different ways

Level 3: I know how many ways there are

Different ways

What could the start and end numbers be?

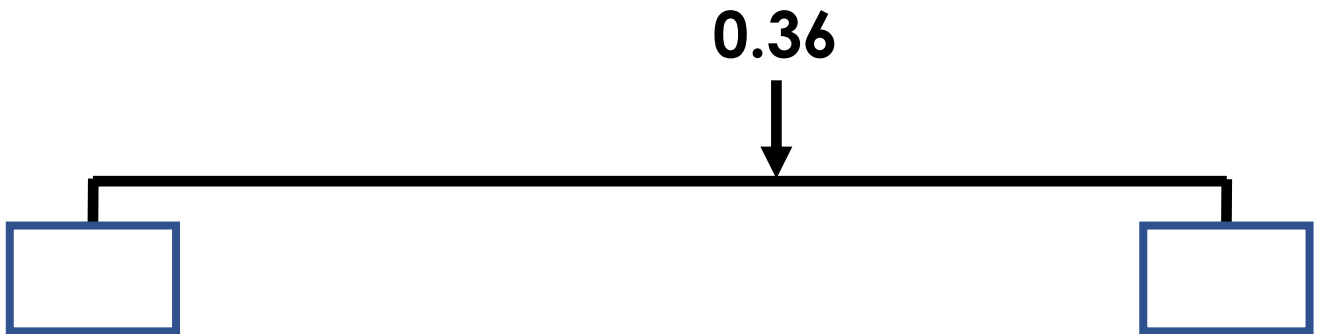

Spot the pattern

5 less than 22 is **17**

5 less than 12 is _____

5 less than 2 is _____

5 less than -8 is _____

Rank by difficulty

What is the difference between:

-70 and 120

-70 and -20

-70 and 160

Estimate

Estimate the value of the hidden numbers.

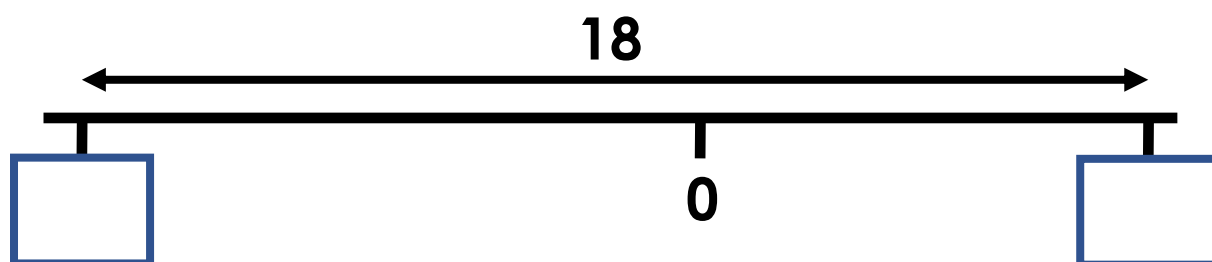

Estimate

Estimate the value of the hidden numbers.

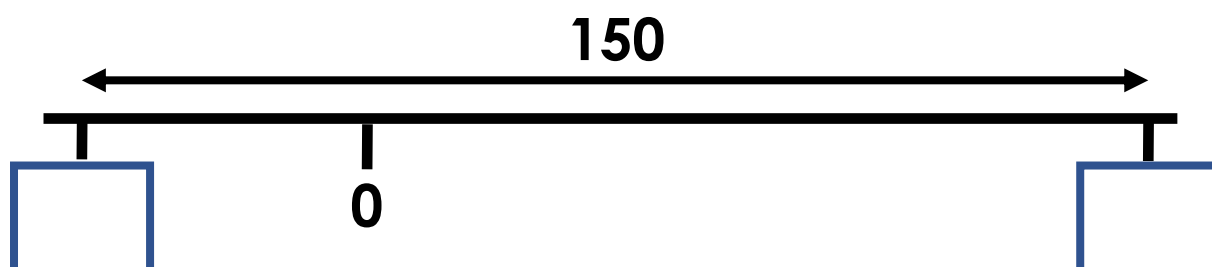

Draw

Draw an arrow to show the position of each number.

-25, 36, -17

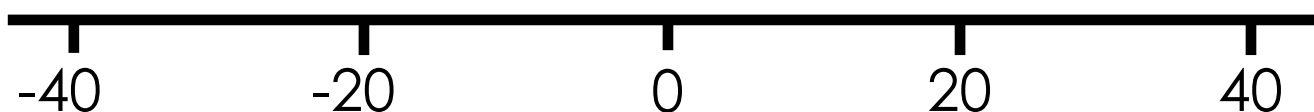

Different ways

The difference between a number and -7 is 12 .

What could the number be?

There are two possible answers!



Show your thinking using the number line.

Explain

'The difference between two numbers can be greater than their sum.'

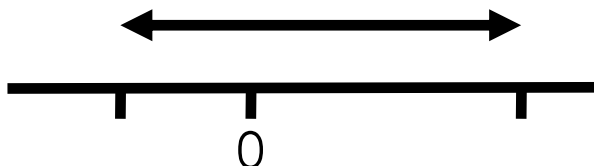

Explain why this is true when one of the numbers is negative.

Different ways

29 is the first number of a sequence.

-3 is the first negative number in the sequence.

Write the first three terms of the sequence.

There is more than one way!

Example:

16, 13, 10...

These are the first three terms in a sequence.

16 is the first number of the sequence.

-2 is the first negative number in the sequence.

True or false?

'Halving a negative number can make it positive.'

'Halving a negative number makes it bigger.'

Which answer?

What is the largest whole number that, when rounded to the nearest 10, is 400?

- (a) 404
- (b) 399
- (c) 449
- (d) 404.9

Which answer?

What is the smallest whole number that, when rounded to the nearest 100, is 3 000?

- (a) 3 001
- (b) 2 950
- (c) 2 500

I know... so...

745 rounded to the nearest 10 is **750**

745 rounded to the nearest 100 is _____

396 rounded to the nearest 10 is _____

396 rounded to the nearest 100 is _____

I know... so...

2074 rounded to the nearest 10 is **2070**

2074 rounded to the nearest 50 is _____

3 165 rounded to the nearest 10 is _____

3 165 rounded to the nearest _____ is 3 160

Explain the mistakes

What is 6 352 to the nearest 100?

Mistake 1: 400

Mistake 2: 6350

Mistake 3: 6300

Explain

‘Numbers can be far apart yet round to the same number’.

Explain, with examples, how this is true.

Explore

When rounded to the nearest  E is 400.

What is the largest whole number E can be?

Explore

A and B are whole numbers.

Rounded to the nearest 100, A is 500

Rounded to the nearest 10, B is 350

What is the smallest possible difference between A and B?

How many ways?

When rounded to the nearest 10, C and D make the same number.

The difference between C and D is 7.

Rounded to the nearest 100, C is 100 and D is 200.

What are the possible values of C and D?

Level 1: I can find a combination for C and D

Level 2: I can find different combinations for C and D

Level 3: I know how many combinations there are for C and D

Rank by difficulty

$$2001 - 48$$

$$130 - 48$$

$$1999 - 48$$

Rank by difficulty

$$2996 + 1650$$

$$3461 + 2537$$

$$4837 + 2189$$

I know... so...

$$200 - 15 = 185$$

$$2000 - 15 = \underline{\hspace{2cm}}$$

$$20000 - 15 = \underline{\hspace{2cm}}$$

I know... so...

$$5001 - 2998 = \underline{\hspace{2cm}}$$

$$5000 - 3000 = 2000$$

$$5003 - \underline{\hspace{2cm}} = 1994$$

Broken calculator

'The 9 and 5 keys on my calculator are broken!'

How can I use it to work out:

$$997 + 995$$

$$457 - 192$$

$$195 + 165$$

Explain the mistakes

Mistake 1

$$12.4 + 6.35$$

$$18.39$$

Mistake 2

$$12.4 + 6.35$$

$$\begin{array}{r} 12.4 \\ + 6.35 \\ \hline 7.59 \end{array}$$

Explain the mistakes

Mistake 1

$$20 - 16.9$$

$$4.1$$

Mistake 2

$$2000 - 70$$

$$1030$$

Mistake 3

$$537 - 294$$

$$\begin{array}{r} 537 \\ - 294 \\ \hline 363 \end{array}$$

Investigate

$$\square\square + \square\square = \square\square\square$$

Stage 1: complete using digits 0-9

Stage 2: complete using digits 1, 2, 3, 5, 6, 7, 9

Investigate

$$\square\square - \square\square = \square\square$$

Stage 1: complete using digits 0-9

Stage 2: complete with the units digit of the first number smaller than the units digit of the second number

How many ways?

Complete using digits 1-9. Use the 7 as shown.

$$\square \square \mathbf{7} = \square + \square + \square + \square$$

Level 1: I can find a way

Level 2: I can find different ways

Level 3: I know how many ways there are

Explain

$$100 - h > 40$$

$$20 + h > 60$$

h is a multiple of 6

List all the numbers h can be.

Explain the mistakes

Mistake 1

$$3.4 \times 100 = 3.400$$

Mistake 2

$$0.7 \times 100 = 700$$

Mistake 3

$$35 \div 10 = 350$$

Mistake 4

$$6.4 \times 10 = 60.4$$

Explain the mistakes

$$63 \times 27$$

Mistake 1

$$60 \times 20 = 1200$$

$$3 \times 7 = 21$$

$$1200 + 21 = 1221$$

Mistake 2

	20	7
60	120	420
3	60	21

$$120 + 420 + 60 + 21 = 621$$

Explain the mistakes

$$163 \times 27$$

Mistake 1

$$\begin{array}{r}
 163 \\
 \times 27 \\
 \hline
 1141 \\
 326 \\
 \hline
 1467
 \end{array}$$

Mistake 2

$$\begin{array}{r}
 163 \\
 \times 27 \\
 \hline
 721 \\
 2260 \\
 \hline
 2981
 \end{array}$$

I know... so...

$$24 \times 18 = 432$$

$$25 \times 18 = \underline{\hspace{2cm}}$$

$$25 \times 17 = \underline{\hspace{2cm}}$$

I know... so...

$$25 \times 48 = \underline{\quad}$$

$$100 \times 48 = 4800$$

$$\underline{\quad} \times 48 = 4848$$

I know... so...

$$60 \times 85 = \underline{\quad}$$

$$240 \times 85 = 20400$$

$$242 \times 85 = \underline{\quad}$$

Broken calculator

'The 8 and 2 keys on my calculator are broken!'

How can I use it to work out:

$$50 \times 28$$

$$25 \times 18$$

Rank by difficulty

$$49 \times 8$$

$$17 \times 8$$

$$25 \times 8$$

Matching number sentences

+ or - number sentence	\times number sentence
$12 + 12 + 18$	6×7
$35 + 14 + 7$	
$160 - 16$	
	12×8

Is it the same?

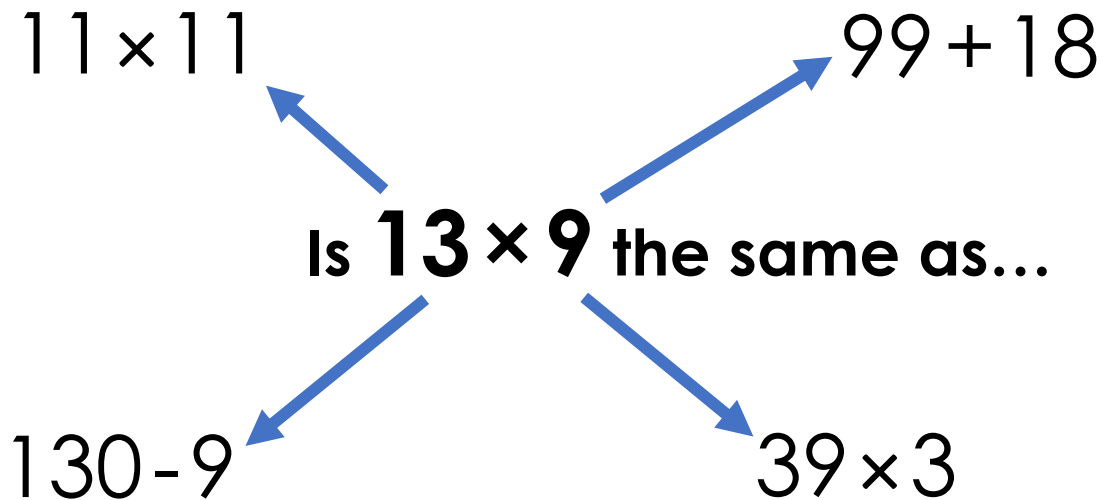

Is it the same?

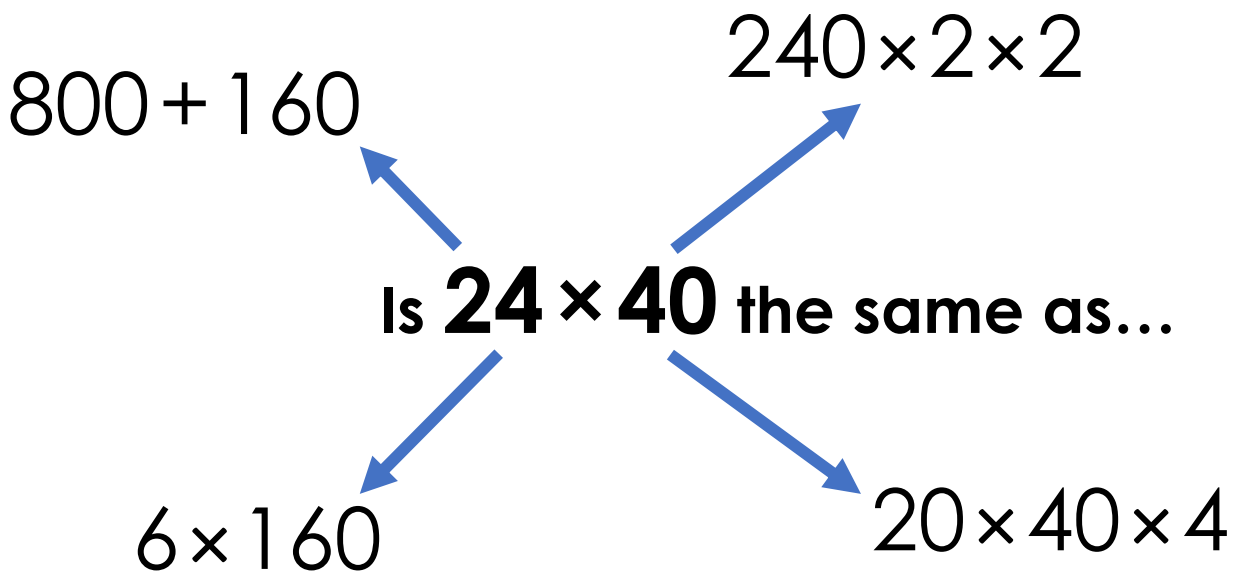

3 ways

$$14 \times 9$$

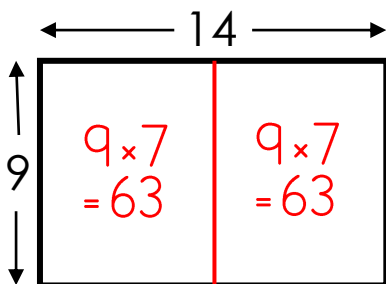

$$63 + 63 = 126$$

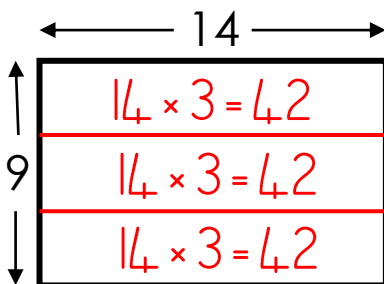

$$42 \times 3 = 126$$

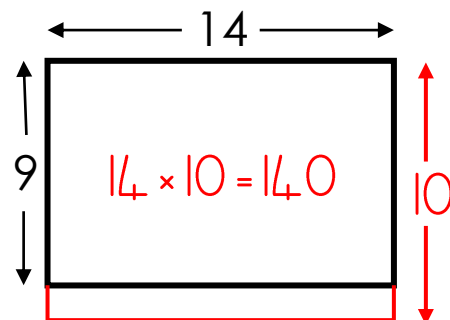

$$140 - 14 = 126$$

Find 3 ways to calculate 15×8 :

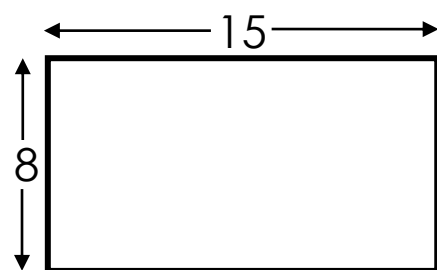
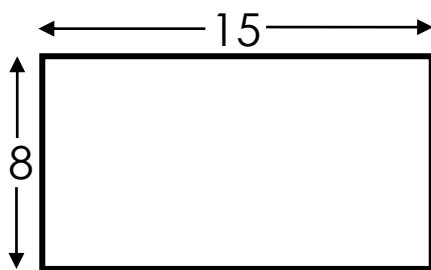
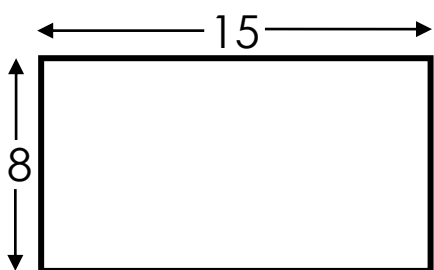

True or false?

$$17 \times 13 = 15 \times 15$$

What do you notice?

Try other examples. Do you see a pattern?

How many ways?

Complete using digits 0-9. The digit in the box with a border must be odd.

$$\square\square \times \square = \square\square$$

Level 1: I can find a way

Level 2: I can find different ways

Level 3: I know how many ways there are

How many ways?

Complete using digits 0-9. Position the digit 1 as shown.

$$\square\square \times \square = \square\square 1$$

Level 1: I can find a way

Level 2: I can find different ways

Level 3: I know how many ways there are

Missing digits

$$\begin{array}{r}
 \square 8 \square \\
 \times 9 \\
 \hline
 7047
 \end{array}$$

Missing digits

$$\begin{array}{r}
 5 \square 3 \\
 \times \square \\
 \hline
 3438
 \end{array}$$

Missing digits

$$\begin{array}{r}
 25\boxed{} \\
 \times \boxed{}7 \\
 \hline
 1771 \\
 7590 \\
 \hline
 9361
 \end{array}$$

Missing digits

$$\begin{array}{r}
 \boxed{}15 \\
 \times 6\boxed{} \\
 \hline
 3260 \\
 48900 \\
 \hline
 52160
 \end{array}$$

Explain

Which can be completed in more ways?

$$\square \times \square \times \square = 28$$

$$\square \times \square \times \square = 34$$

Explore

Put a number in each section of the Venn diagram.

even numbers

prime numbers

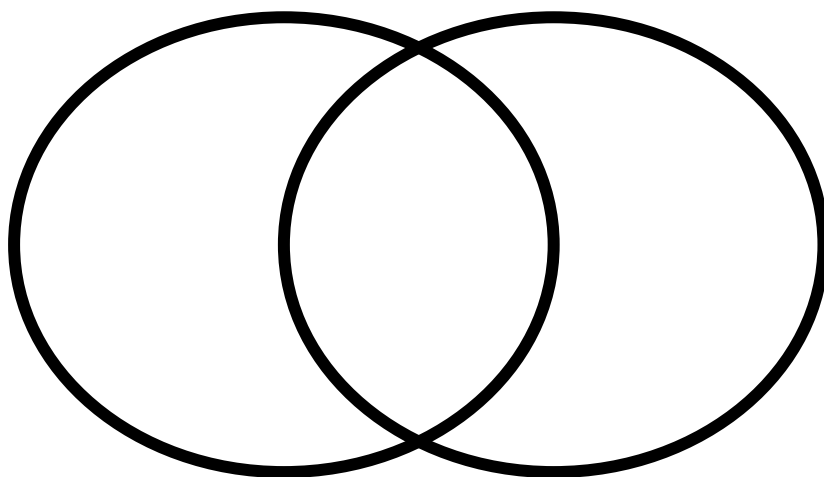

How many numbers can go in the middle section?

Explore

Position the headings. Put a number in each section.

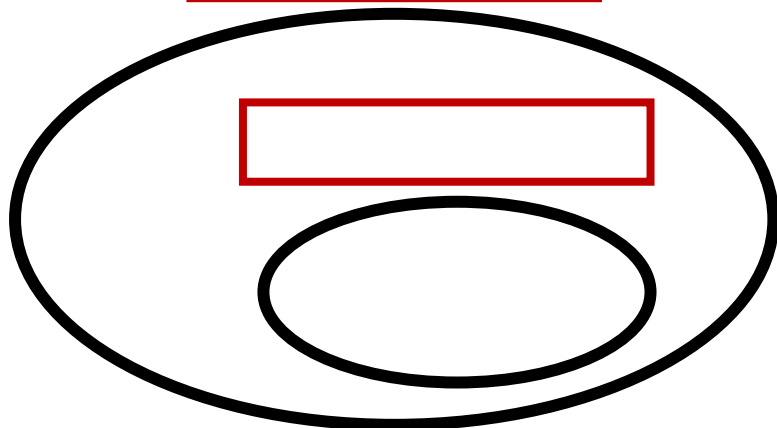
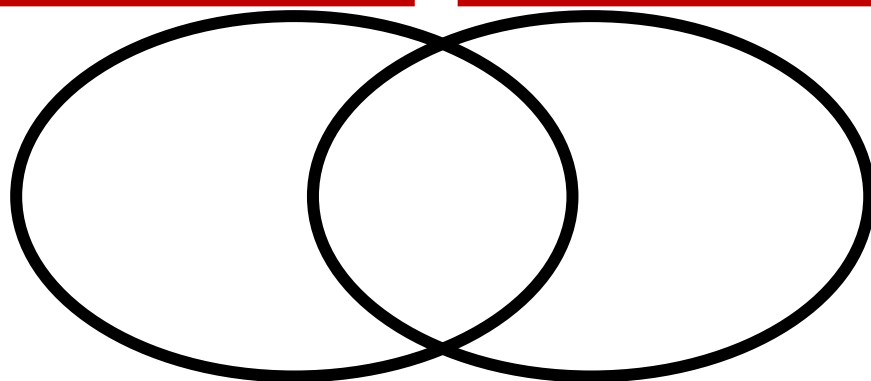

Headings:

Multiples of 7

Multiples of 3

Multiples of 12

Even numbers

True or false?

'Odd square numbers greater than 1 have three factors.'

Rank by difficulty

$$693 \div 7$$

$$300 \div 7$$

$$287 \div 7$$

$$5600 \div 7$$

Rank by difficulty

$$200 \div 24$$

$$500 \div 24$$

$$120 \div 24$$

$$72 \div 24$$

I know... so...

$$78 \div 6 = \underline{\quad}$$

$$74 \div 6 = 12 \text{ remainder } 2$$

$$\underline{\quad} \div 6 = 11 \text{ remainder } 5$$

I know... so...

$$288 \div 12 = \underline{\quad}$$

$$300 \div 12 = 25$$

$$\underline{\quad} \div 12 = 25\frac{1}{6}$$

I know... so...

$$45 \div 8 = \underline{\quad}$$

$$46 \div 8 = 5\frac{3}{4}$$

$$\underline{\quad} \div 8 = 6\frac{1}{8}$$

Explain the mistakes

$$564 \div 3$$

Mistake 1

$$\begin{array}{r} 121 \\ 3 \overline{)564} \end{array}$$

Mistake 2

$$\begin{array}{r} 194 \text{ r } 2 \\ 3 \overline{)564} \end{array}$$

Mistake 3

$$\begin{array}{r} 187 \\ 3 \overline{)564} \end{array}$$

Explain the mistakes $544 \div 16$

Mistake 1

$$\begin{array}{r}
 16 \overline{) 544} \\
 \underline{-480} \quad (16 \times 30) \\
 164 \\
 \underline{-160} \quad (16 \times 10) \\
 4 \\
 = 40 \text{ r } 4
 \end{array}$$

Mistake 2

$$\begin{array}{r}
 16 \overline{) 544} \\
 \underline{-480} \quad (16 \times 30) \\
 64 \\
 \underline{-54} \quad (16 \times 4) \\
 10 \\
 = 34 \text{ r } 10
 \end{array}$$

Explain the mistakes $3432 \div 24$

Mistake 1

$$\begin{array}{r}
 43 \\
 24 \overline{) 3432} \\
 \underline{24} \\
 103 \\
 \underline{96} \\
 \underline{72} \\
 \underline{72} \\

 \end{array}$$

Mistake 2

$$\begin{array}{r}
 13 \\
 24 \overline{) 3432} \\
 \underline{24} \\
 103 \\
 \underline{72} \\
 \underline{312} \\
 ?
 \end{array}$$

Form of answer

It took Fiona 93 hours to write a children's book. She worked for 12 days. On average, how long did she spend writing each day?

(a) 7.9 hours

(b) 8 hours

(c) 7 hours 45 minutes

Form of answer

$$6 \overline{) 82} \begin{array}{r} 13 \\ r 4 \end{array}$$

Question	Answer
Eggs are packed in boxes of 6. The farmer has 82 eggs. How many boxes does he need?	14 boxes
A sunflower grows to a height of 82cm in 6 weeks. On average, how many centimetres does it grow each week?	
82 children turn up for a 6-a-side football tournament. How many teams can be made? Teams can have substitutes.	
An artist works on a masterpiece for 82 hours over 6 days. On average, how long does she work each day?	

Broken calculator

'The 7 and 5 keys on my calculator are broken!'

How can I use it to work out:

$$160 \div 5$$

$$72 \div 4$$

True or false?

'It's impossible to divide a number by 3 more than twice without leaving a remainder.'

Explain using examples.

How many ways?

$$60 \div \underline{\quad} = 12 \div \underline{\quad}$$

Complete using positive whole numbers.

Level 1: I can find a way

Level 2: I can find different ways

Level 3: I know how many ways there are

How many ways?

Level 1: complete using digits 0-9.

$$\square\square \div \square = \square \text{ remainder } \square$$

Level 2: complete, using the 7 as 2 as shown.

$$\square\square \div 7 = \square \text{ remainder } 2$$

Level 3: how many ways can level 2 be done?

How many ways?

Complete using digits 0-9. Position the digits 1, 2 and 4 as shown.

$$\square\square \div 4 = \square \frac{1}{2}$$

Level 1: I can find a way

Level 2: I can find different ways

Level 3: I know how many ways there are

True or false?

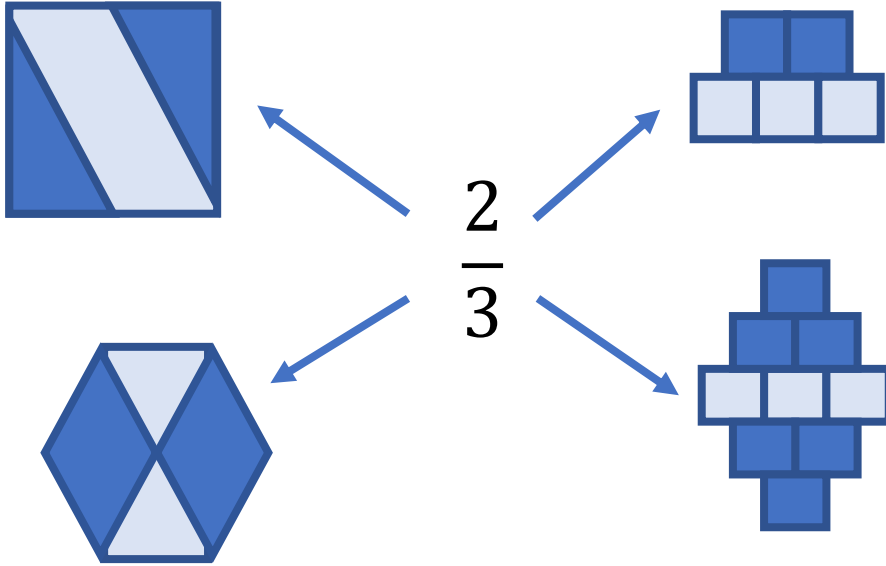

Explain the mistake

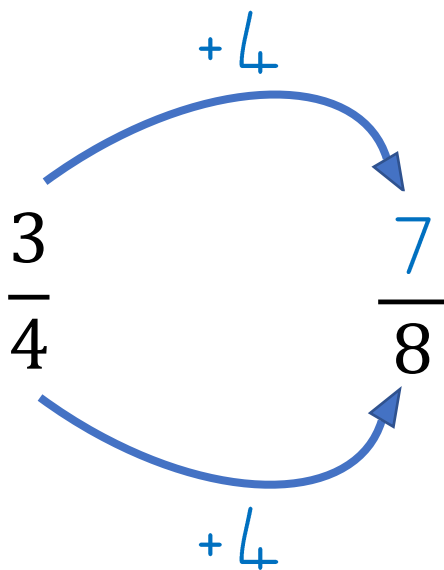

Explain

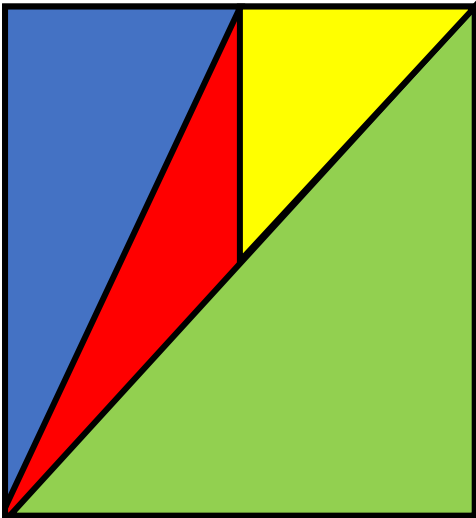

Which fractions do you see?

Explain

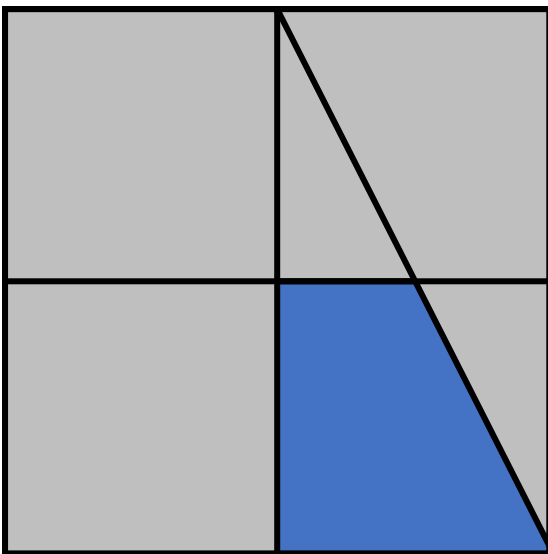

What fraction of the square is blue?

Different ways

Which fractions could be at either end of the number line?

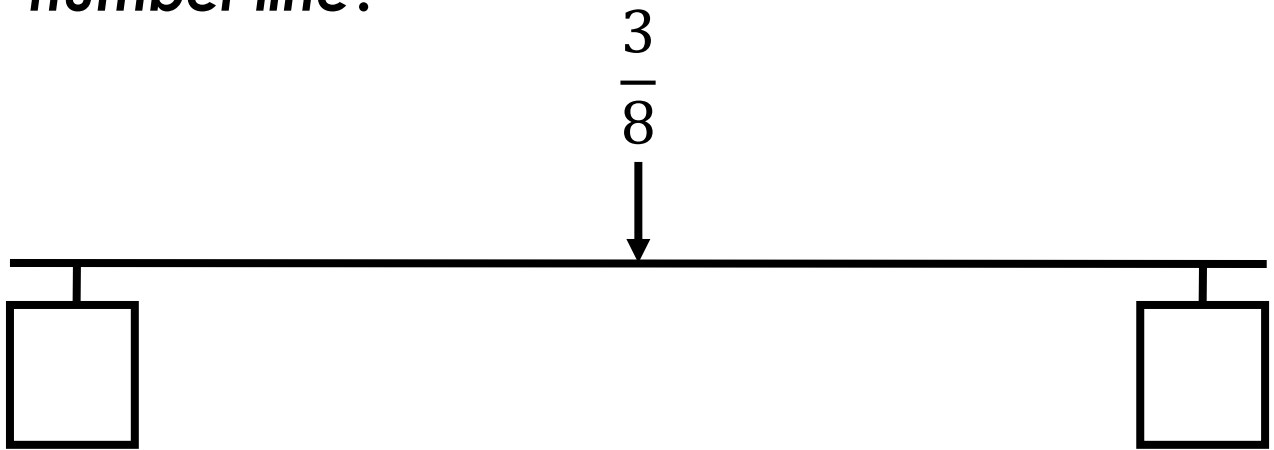

How many ways?

Complete the fractions using three of the number cards.

$$\frac{\square}{8} > \frac{\square}{\square}$$

3

4

5

6

I know... so...

$$2 \frac{1}{5} = \frac{\square}{5}$$

$$2 \frac{4}{5} = \frac{14}{5}$$

$$3 \frac{1}{5} = \frac{\square}{\square}$$

Explain

How many quarters in $3\frac{1}{2}$?

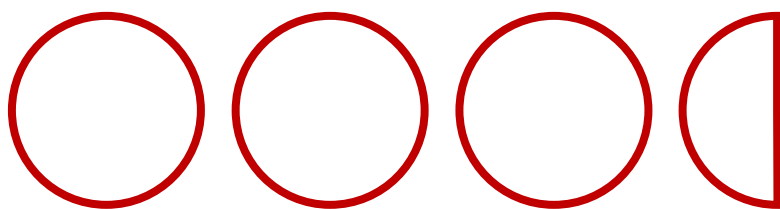

(a) 14

(b) 2

(c) 7

Explore

Write these fractions in the correct section of the Venn diagram:

$$\frac{3}{6}$$

$$\frac{4}{10}$$

$$\frac{3}{5}$$

$$\frac{7}{8}$$

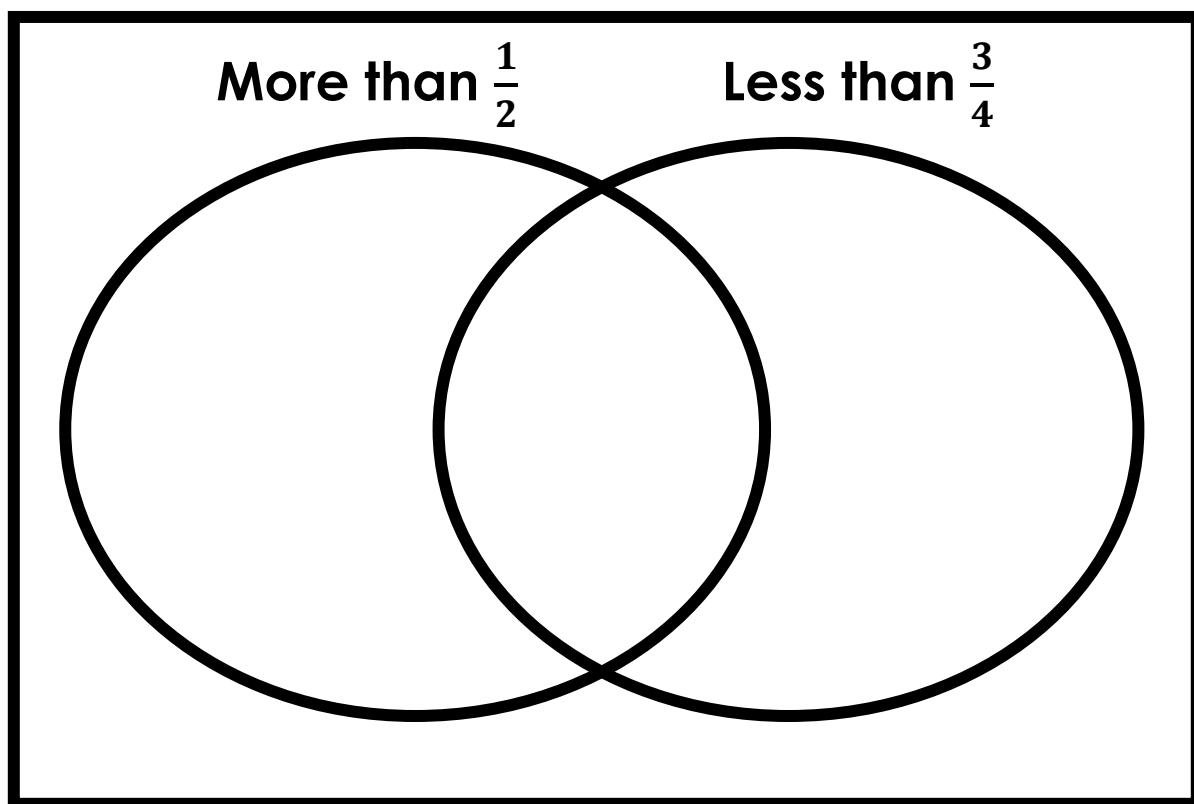

Add some of your own fractions

Different ways

Fill in the gaps. Find different ways.

$$\frac{\boxed{5}}{4} = \boxed{1} \frac{\boxed{1}}{4} \rightarrow \bigoplus \quad \triangle$$

$$\frac{\boxed{}}{4} = \boxed{} \frac{\boxed{}}{4}$$

$$\frac{\boxed{}}{4} = \boxed{} \frac{\boxed{}}{4}$$

Different ways

Use the digits 2, 3, 4, 5, 6.

How many fractions can be made for each section?

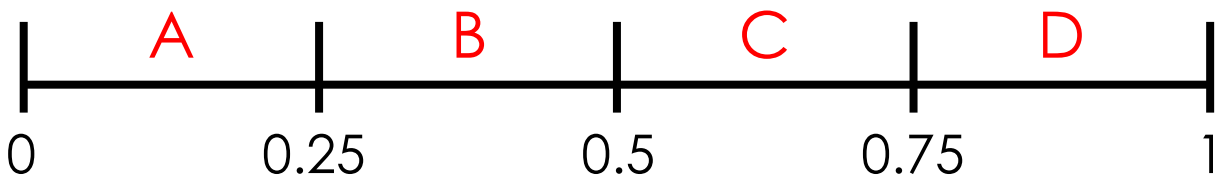

Example: $\frac{2}{3}$ is in section C

How many ways?

Make all the fractions that are more than 50% and less than 75% using these digits:

3, 4, 5, 6, 8

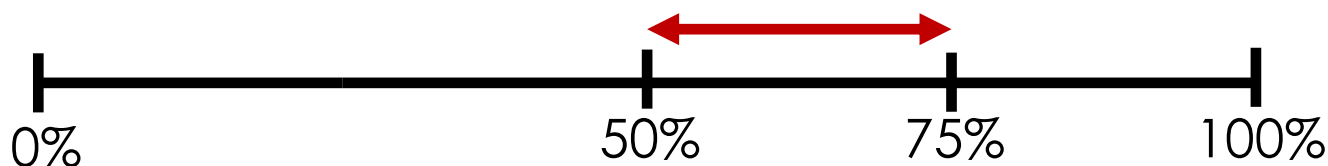

I know... so...

$$\frac{1}{7} \text{ of } 168 = \square$$

$$\frac{2}{7} \text{ of } 168 = 48$$

$$\frac{2}{7} \text{ of } \square = 96$$

I know... so...

$$\frac{1}{8} \text{ of } 248 = \square$$

$$\frac{1}{4} \text{ of } 248 = 62$$

$$\frac{3}{4} \text{ of } 248 = \square$$

Different ways

Fill in the gaps. Find different ways.

$$\frac{2}{\boxed{5}} \text{ of } \boxed{60} = 24$$

$$\frac{2}{\boxed{}} \text{ of } \boxed{} = 24$$

$$\frac{2}{\boxed{}} \text{ of } \boxed{} = 24$$

$$\frac{2}{\boxed{}} \text{ of } \boxed{} = 24$$

Which picture?

Draw lines to match the questions to the bar models:

$$60 \div 4$$

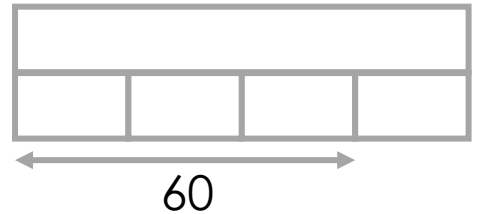

$\frac{3}{4}$ of a number is 60.
What is the number?

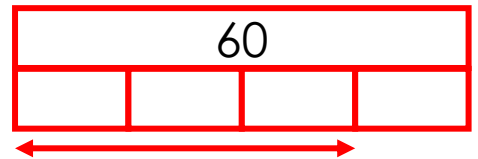

$$\frac{3}{4} \text{ of } 60$$

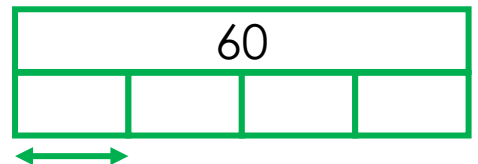

Explain the mistake

$$\frac{3}{6} + \frac{1}{3} = \frac{4}{9}$$

Rank by difficulty

$$\frac{3}{9} + \frac{7}{9}$$

$$\frac{3}{6} + \frac{5}{10}$$

$$\frac{1}{5} + \frac{3}{10}$$

$$\frac{4}{7} + \frac{2}{7}$$

$$\frac{1}{3} + \frac{2}{5}$$

How many ways?

$$\frac{\square}{8} + \frac{1}{\square} = \frac{\square}{4}$$

The answer must be a proper fraction

Level 1: I can find a way

Level 2: I can find different ways

Level 3: I know how many ways there are

How many ways?

$$\frac{1}{5} + \frac{2}{\square} = \frac{\square}{20}$$

The answer must be a proper fraction

Level 1: I can find a way

Level 2: I can find different ways

Level 3: I know how many ways there are

Explain the mistake

$$\frac{3}{4} \times 5 = \frac{15}{20}$$

Rank by difficulty

$$\frac{1}{4} \times 5$$

$$\frac{3}{10} \times 3$$

$$\frac{3}{4} \times 3$$

How many ways?

$$\frac{\square}{4} \times \square = 3 \frac{3}{4}$$

Level 1: I can find a way

Level 2: I can find different ways

Level 3: I know how many ways there are

I know... so...

$$\frac{3}{5} \times 4 = \square \frac{\square}{\square}$$

$$\frac{3}{5} \times 6 = 3\frac{3}{5}$$

$$\frac{3}{5} \times 7 = \square \frac{\square}{\square}$$

Explain

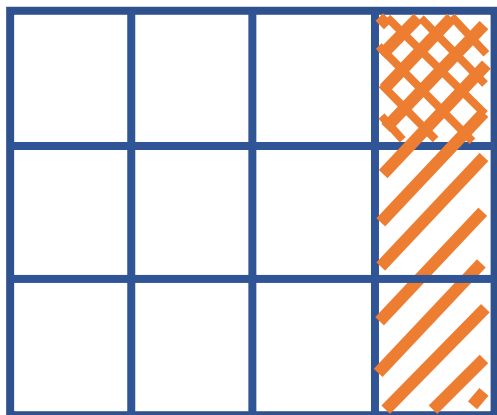

Explain how this picture shows

$$\frac{1}{4} \times \frac{1}{3}$$

How many ways?

$$\frac{\square}{4} \times \frac{1}{\square} = \frac{\square}{8}$$

All three fractions are proper fractions

Level 1: I can find a way

Level 2: I can find different ways

Level 3: I know how many ways there are

Rank by difficulty

$$\frac{2}{3} \div 4$$

$$\frac{4}{5} \div 4$$

$$\frac{1}{5} \div 4$$

I know... so...

$$\frac{3}{4} \div 2 = \frac{3}{8}$$

$$\frac{3}{4} \div 3 = \frac{1}{\square}$$

$$\frac{3}{4} \div 4 = \frac{\square}{16}$$

Which picture?

$\frac{2}{3}$ of the children in the running club are girls.

There are 45 children in the running club.

How many girls are in the running club?

Which drawing(s) represent this question correctly?

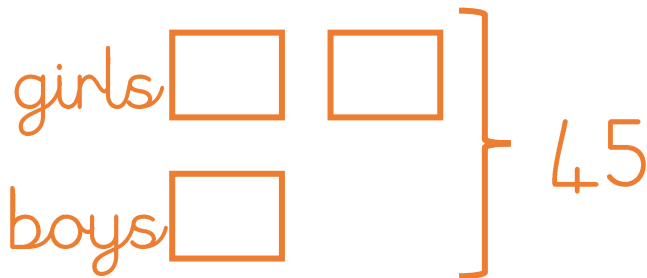
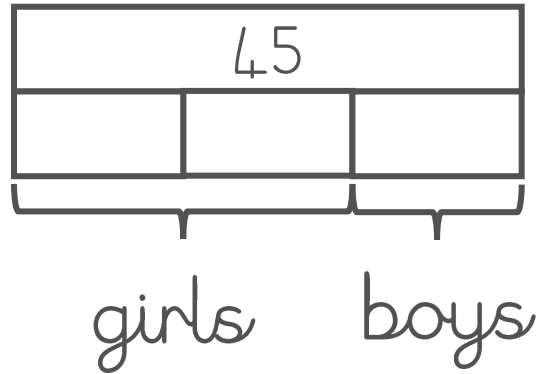
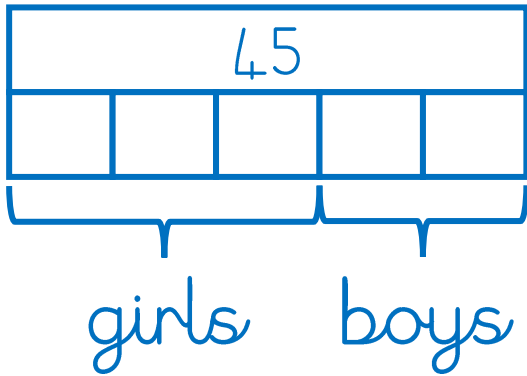

Which picture?

For every five children in the school who are right-handed, there is one left-handed child. There are 300 right-handed children in the school. How many left-handed children?

Who do you agree with?

Jen's method 300

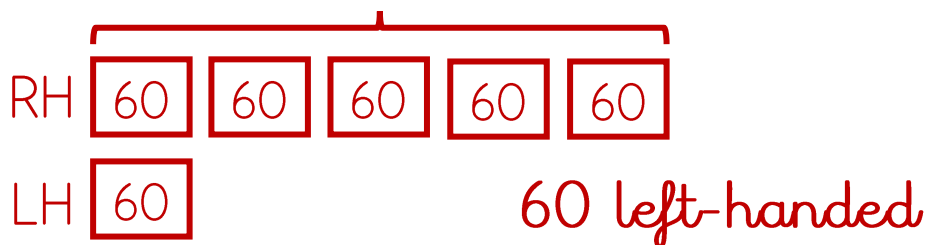

Rhian's method



Different ways

To calculate 85% of 260 you have worked out:

$$50\% = 130$$

$$25\% = 65$$

$$10\% = 26$$

$$5\% = 13$$

Using this information, calculate 85% of 260 in three different ways.

Explain

Here is a sequence of numbers: **3, 10, 17...**

*170 is in this sequence
as $10 \times 17 = 170$*

Do you agree with this statement?

Explain

Here is a sequence of numbers: **1, 5, 9, 13...**

*26 is in the sequence
because it is double 13*

Explain why this statement is incorrect.

If I know... then I know...

$$6e + 4 = f$$

When $e = 6$, $f = \square$

When $e = 8$, $f = 52$

When $e = \square$ $f = 58$

Which answer?

$$3c - 4 = d$$

When $c = 6$, what is the value of d ?

(a) $d = 32$

(b) $d = 14$ Explain how you know.

(c) $d = 5$

Which one?

It costs £6 to hire a wetsuit plus £4 per hour used.

It costs £4 to hire a surfboard plus £6 per hour used.

h = hours used

$£4h + £6$ = cost to hire a _____

$£6h + £4$ = cost to hire a _____

Fill in the gaps with the correct words.

Explain

$$100 - 5n > 60$$

n is a whole number

Level 1: I can find a possible value for n

Level 2: I can find the largest possible value for n

Explain

How many possible values for s in each equation?

Equation	One possible value for s	More than one possible value for s	Infinite possible values for s
$50 > 6s$		✓	
$25 < 20 + s$			
$5s - 2 = 18$			
$5s + 2 = t$			

s is a positive whole number

Explain the mistakes

$$23\text{cm} = \underline{2.3} \text{ mm}$$

$$3.05\text{m} = \underline{300.5} \text{ cm}$$

$$740\text{m} = \underline{7.4} \text{ km}$$

Rank by difficulty

8 kilometres is approximately 5 miles

40 miles = _____ kilometres

1 kilometre = _____ miles

20 kilometres = _____ miles

Explore

Write these measures in the correct section of the Venn diagram:

pounds metres grams pints miles

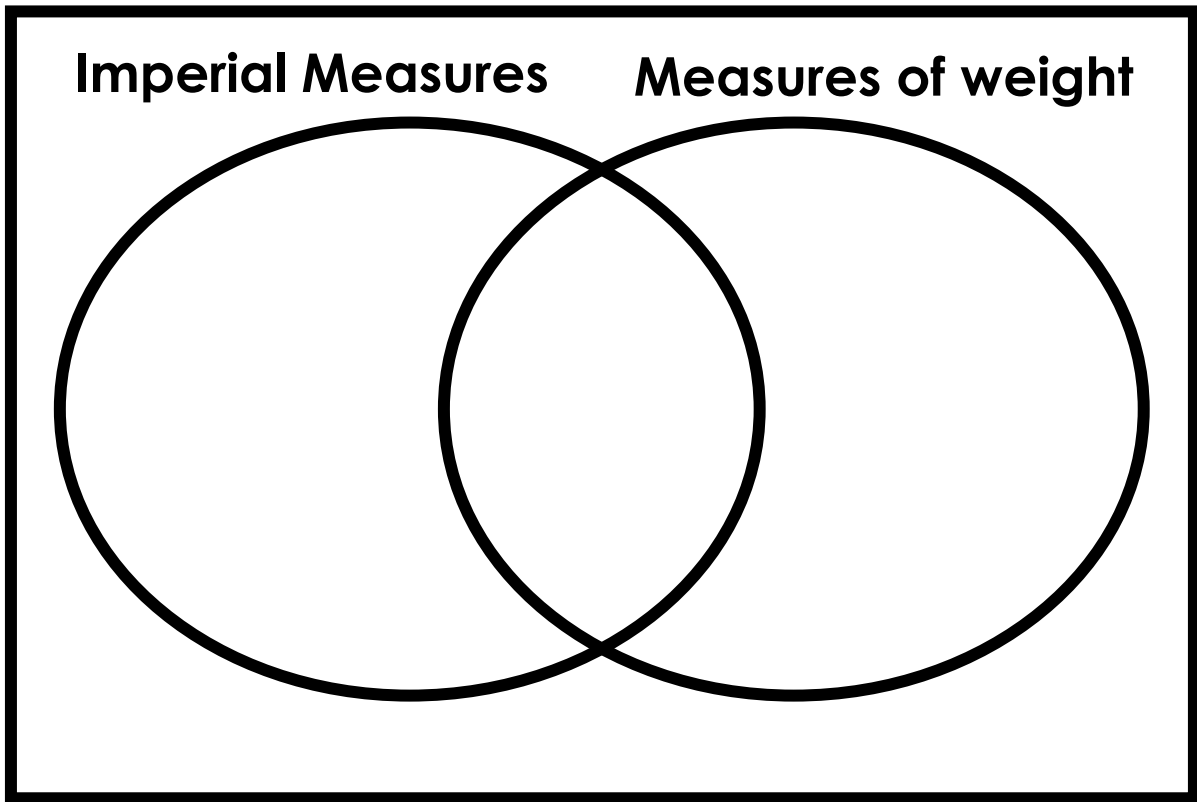

Add some more units of measure

Explore

Write the headings for the Venn diagram

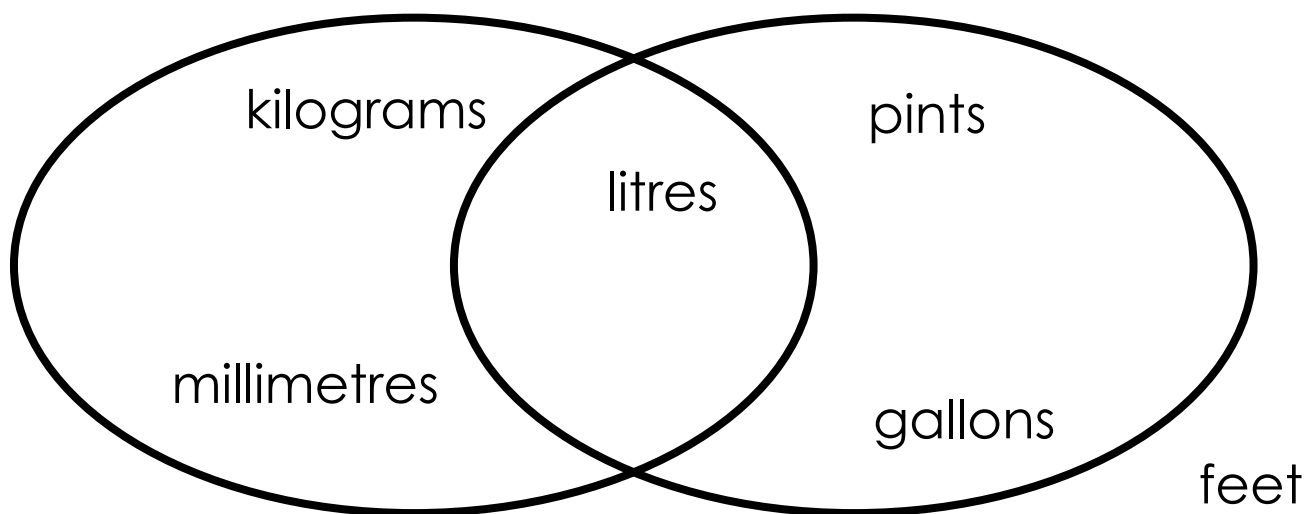

Add other units of measure to the diagram

Order

Order the following from shortest to longest:

400 minutes

$\frac{1}{3}$ of a day

6 hours

18000 seconds

Explain the mistakes

Tom arrived at the airport at 3:40pm. The drive to the airport took him $\frac{3}{4}$ hour. At what time did Tom set off?

Mistake 1

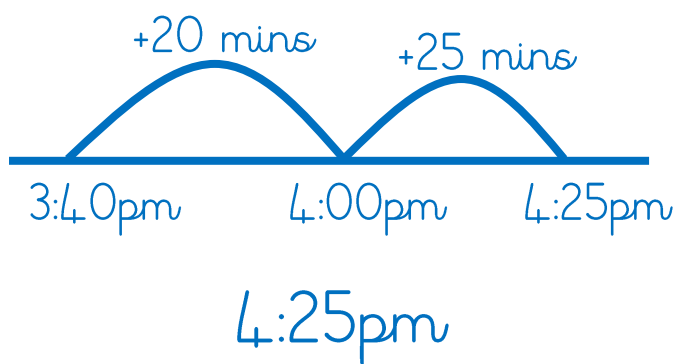

Mistake 2

$$\begin{array}{r}
 2\ 13 \\
 \cancel{3:40} \\
 -\ 45 \\
 \hline
 2:95 \\
 \hline
 \end{array}$$

Rank by difficulty

200 minutes = ____ hours ____ minutes

200 hours = ____ days ____ hours

200 days = ____ months ____ days

Estimate

Estimate the length, width and height of each cuboid:

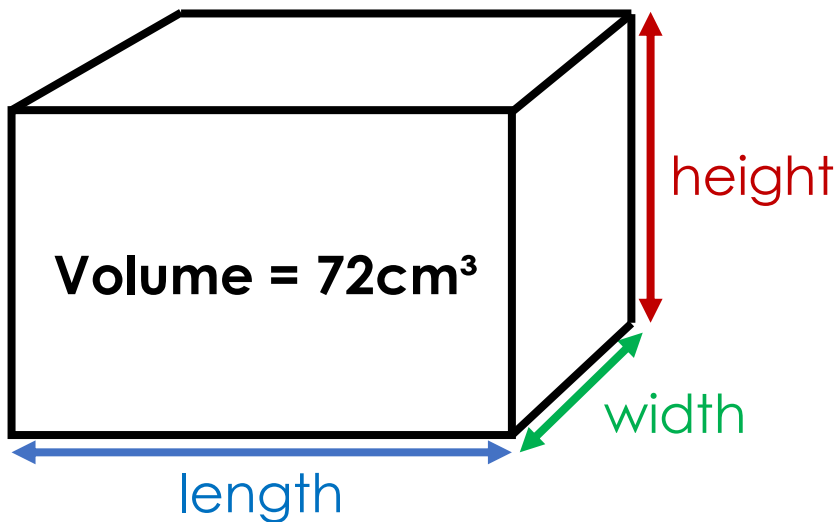
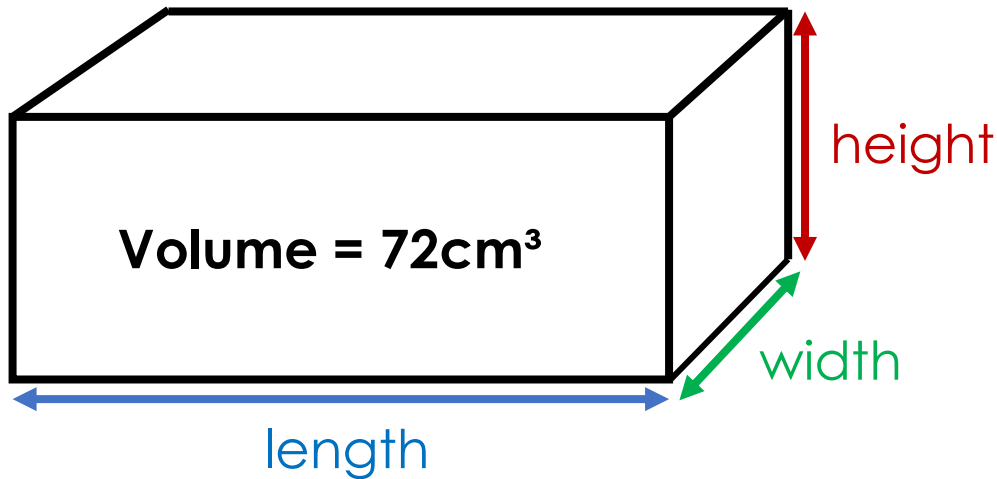

Estimate

The cube is full of water.

The water will be poured into the cuboid.

Estimate the height that the water will reach in the cuboid.

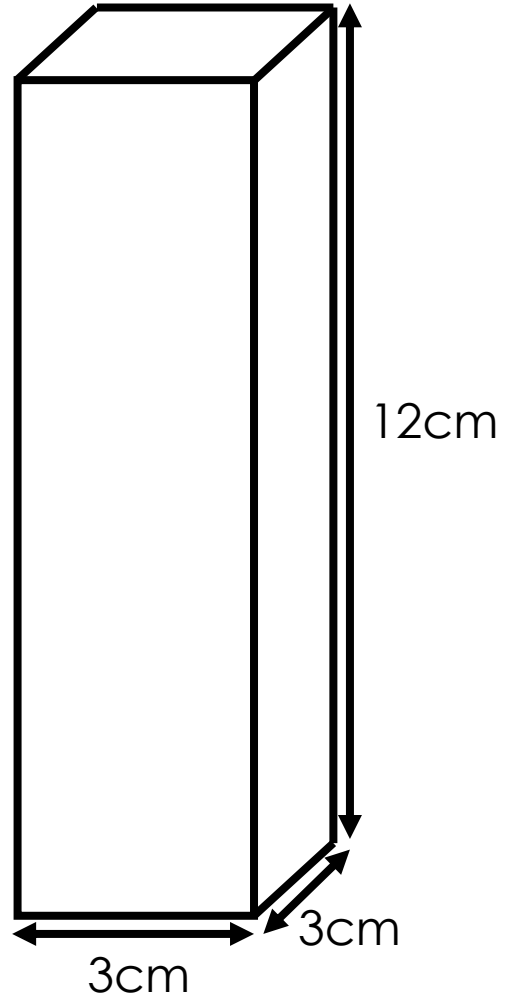
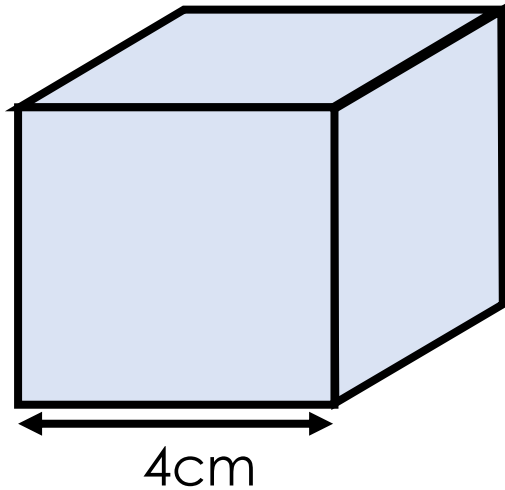

Estimate

Estimate the perimeter of the rectangle:

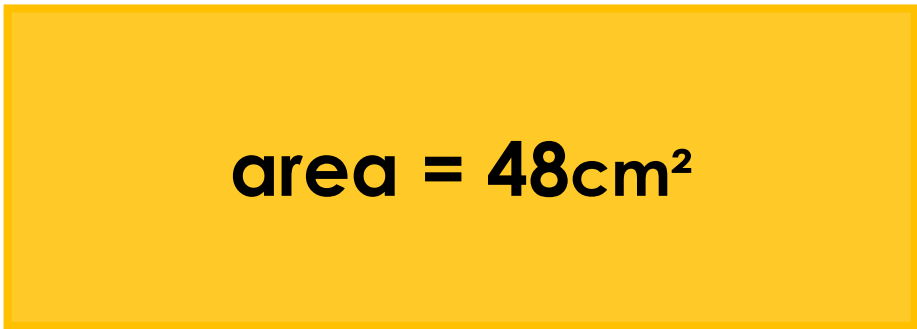

I know... so...

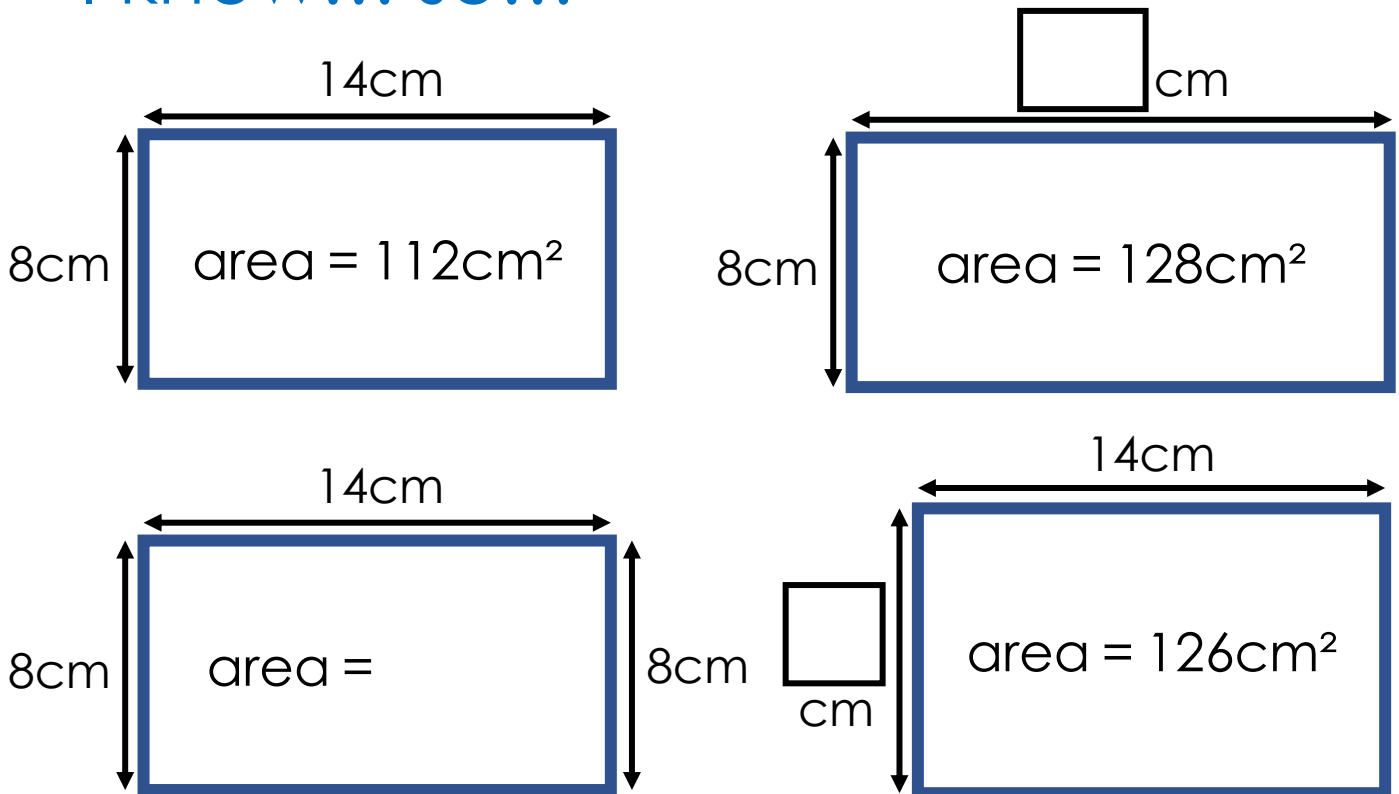

Explain

Here are two identical rectangles.

Put them together to make one shape. Make the perimeter of the new shape as small as possible.



I know... so...

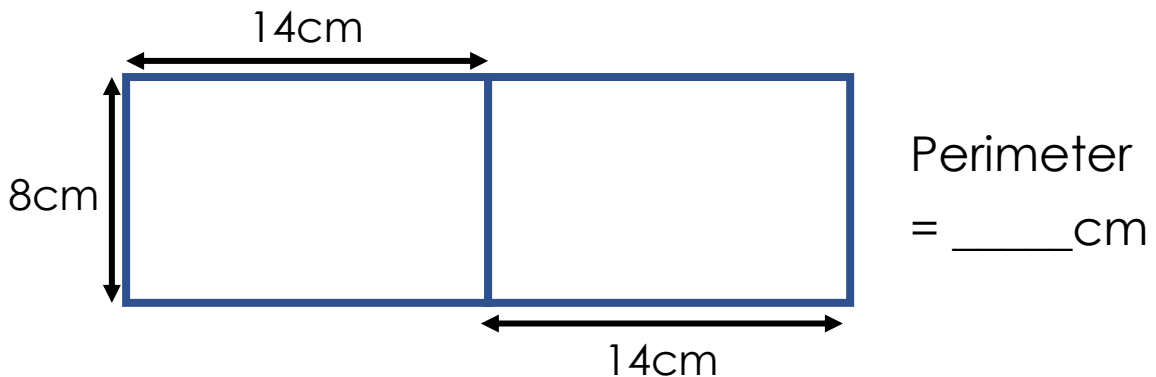
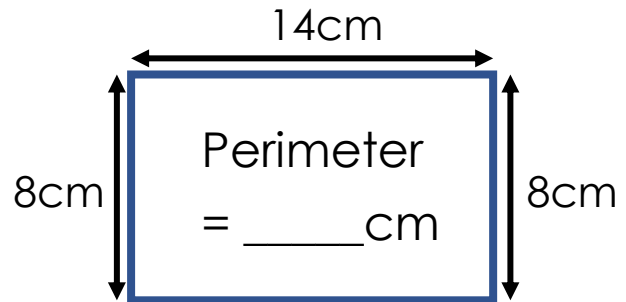
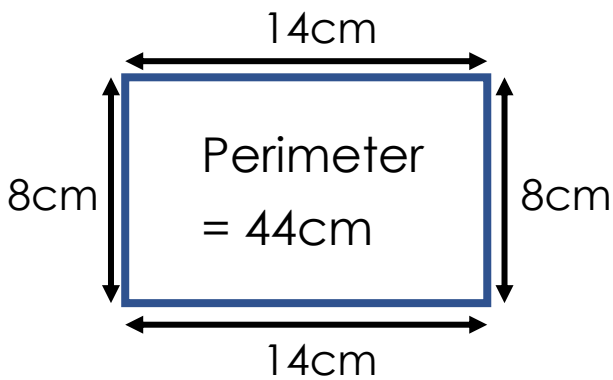

Explain

The area of the large square is 100cm^2 .

The perimeter of the small square is half the perimeter of the large square.

What is the area of the small square?



Spot the mistake

What is the area of the shape?

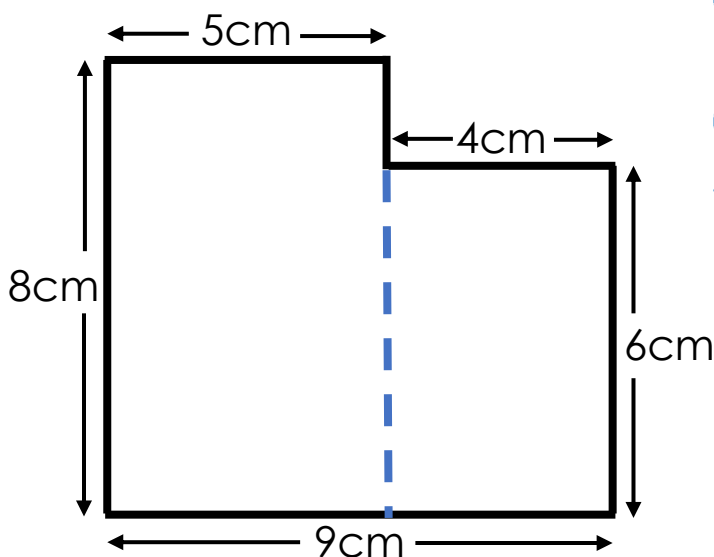

$$9 \times 8 = 72$$

$$6 \times 4 = 24$$

$$72 + 24 = 96\text{cm}^2$$

Draw

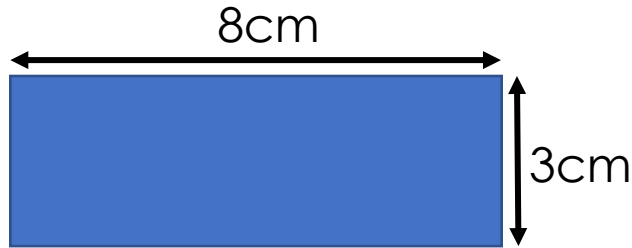

Draw a rectangle with...

...a smaller area and a larger perimeter:

...the same perimeter and a larger area:

Different ways

What area is orange?

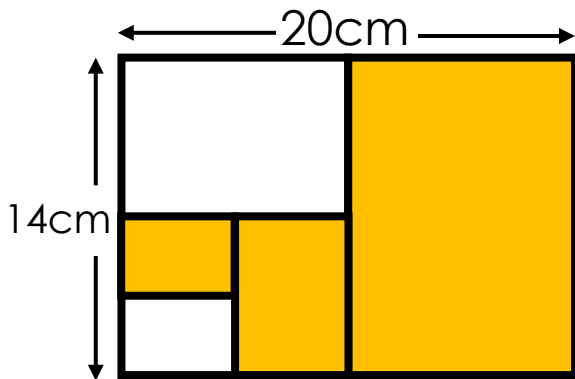

Can you work it out in different ways?

Which answer?

What is the area of the right-angled triangle?

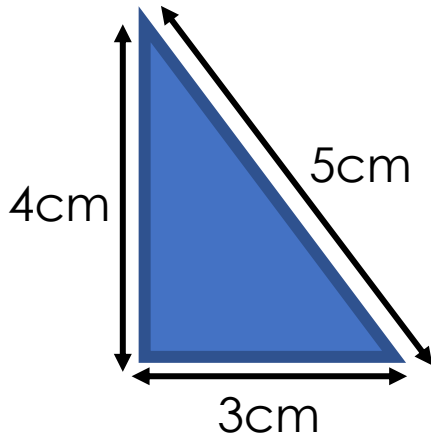

(a) 6cm^2

(b) 7.5cm^2

(c) 12cm^2

Different ways

The red spot is in the centre of the rectangle.

What is the area of the blue section?

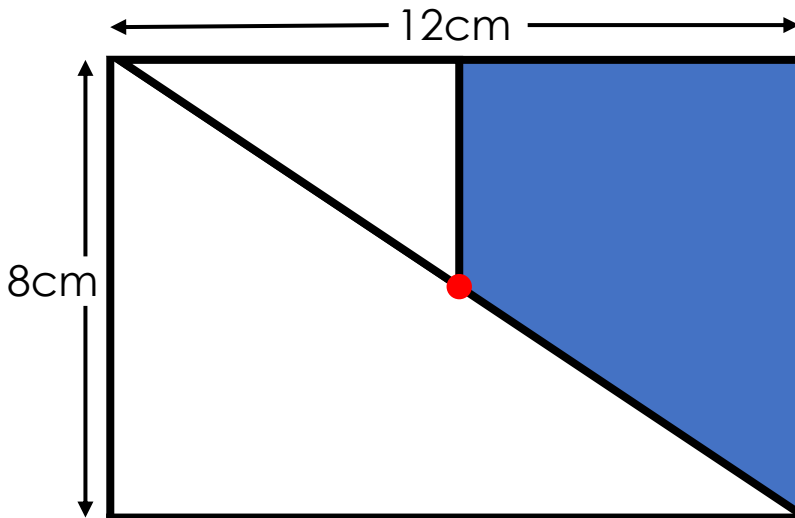

Can you work it out in different ways?

Odd one out

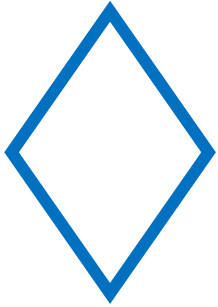

Explore

Write the headings for the Venn diagram

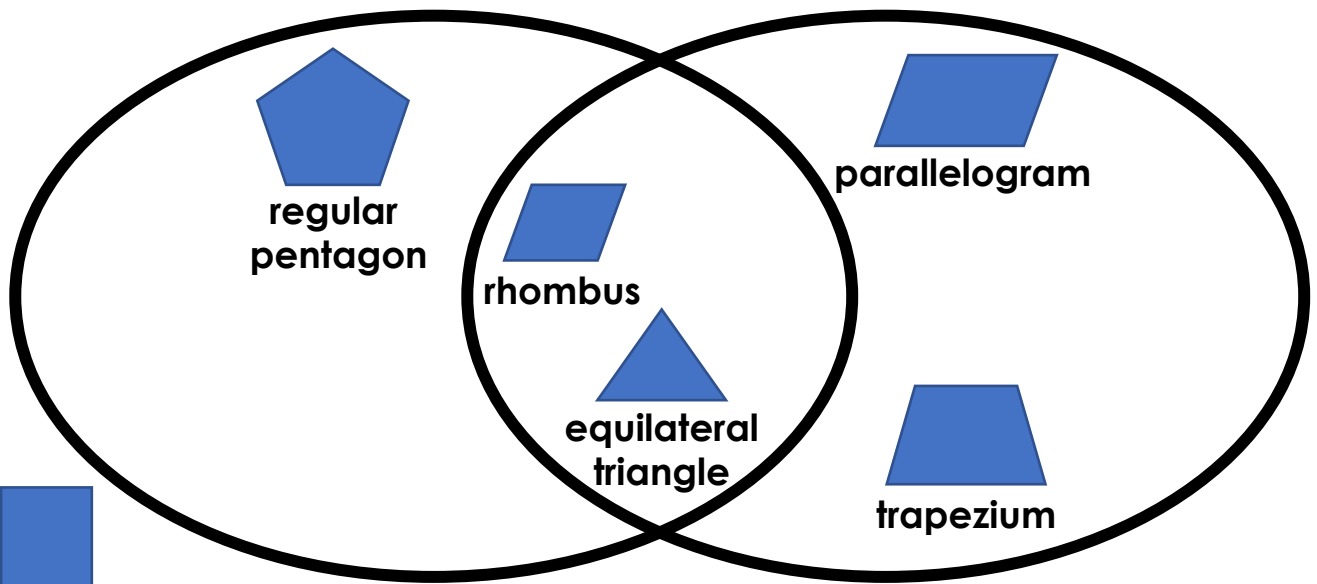

Add other shapes to the diagram

Explore

Write the questions in the branching database:

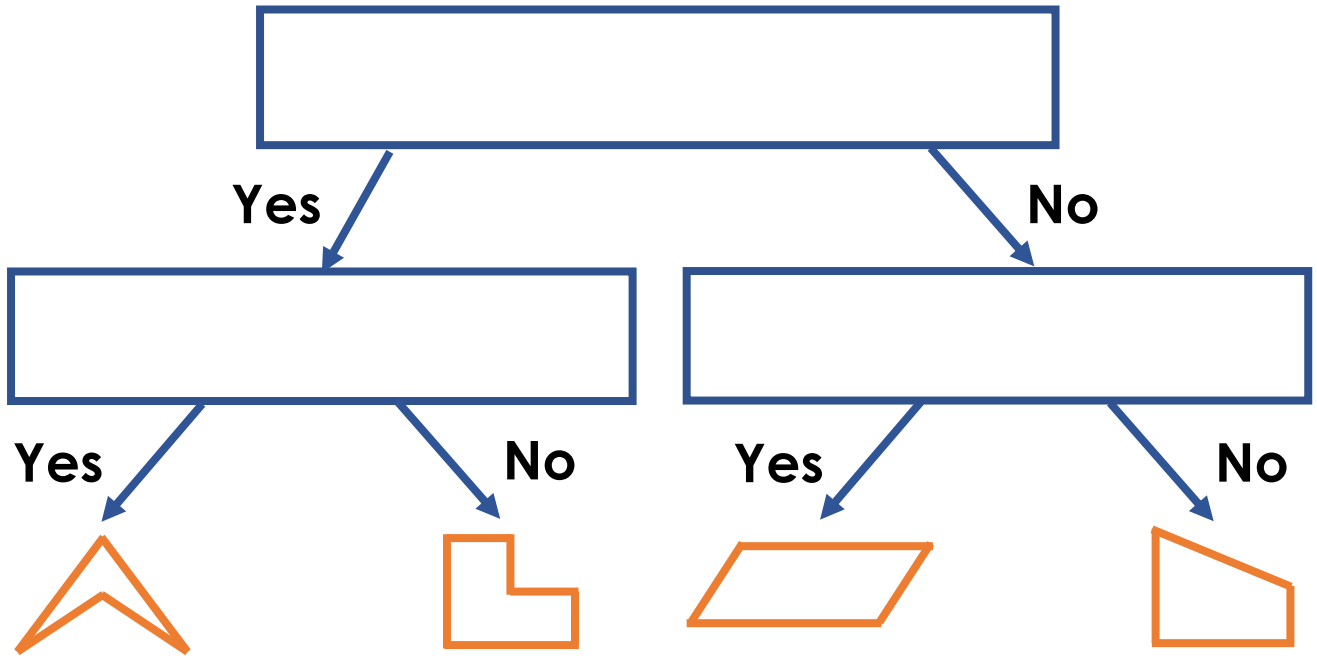

Odd one out



cuboid

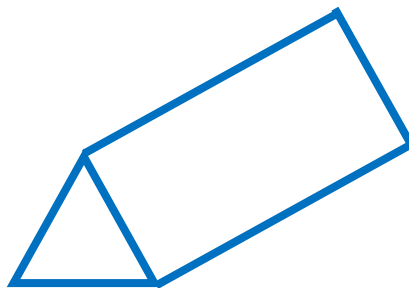

triangular prism

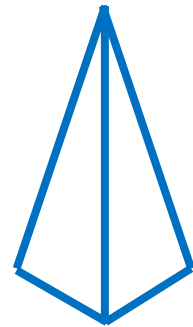

square-based
pyramid

Fill the gaps

Fill in the missing spaces in the table:

Name of 3D Shape	Edges	
	6	4
Hexagonal prism		8

Fill the gaps

Fill in the missing spaces in the table:

Name of 3D Shape	Faces	
Cuboid		8
	5	6
Square-based pyramid		

Different ways

This pyramid is made using four equilateral triangles.

Draw one more triangle on each diagram to complete the net for the pyramid. Find three different ways it can be done.

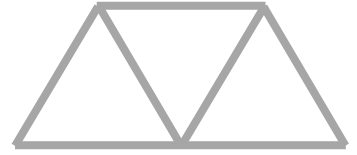
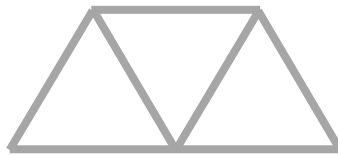
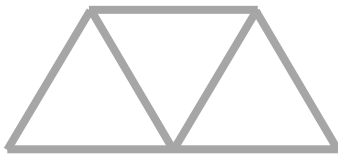
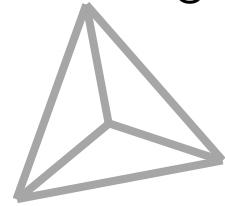

It is correct?

One more square needs adding to this diagram to make the net of a cube.

Which diagrams have been completed correctly to make the net of a cube?

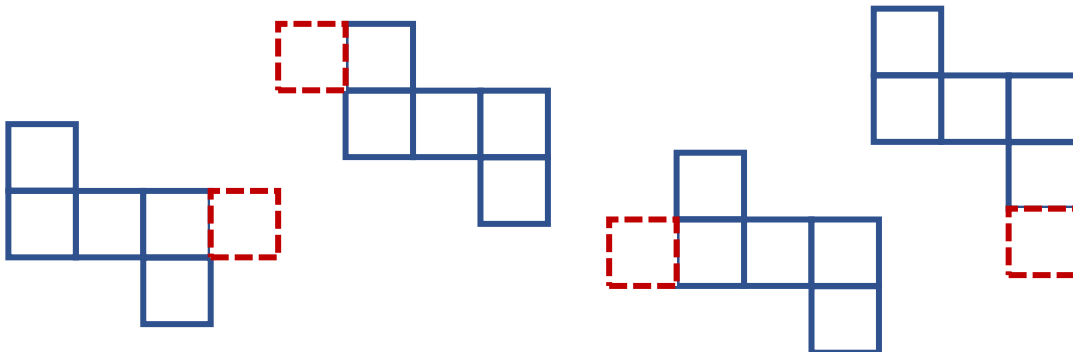
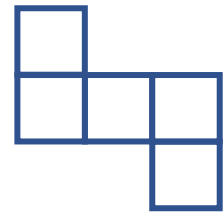

Explain the mistakes

Reflect the shape in the mirror line.

Mistake 1

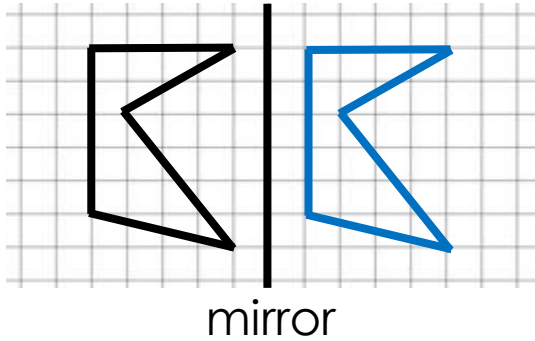

Mistake 3

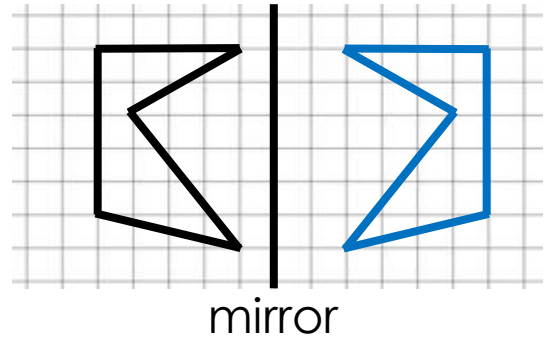

Mistake 2

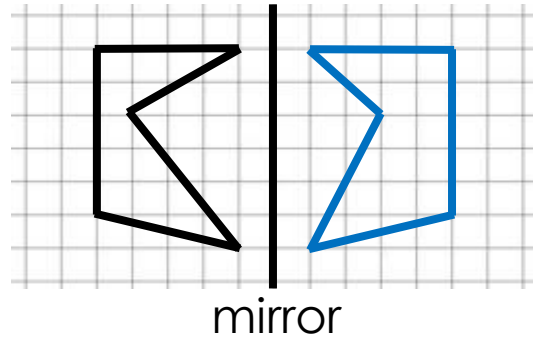

Explain the mistakes

Translate 3 squares to the right and 4 squares up.

Mistake 1

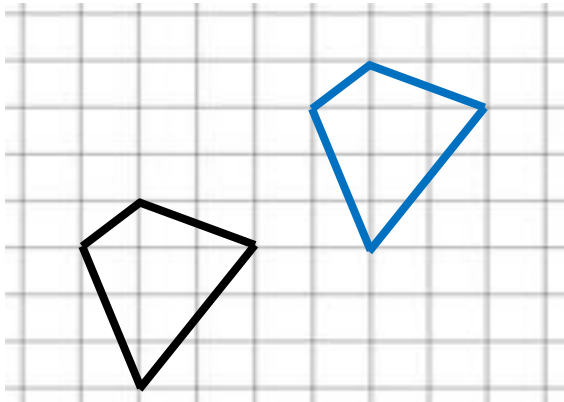



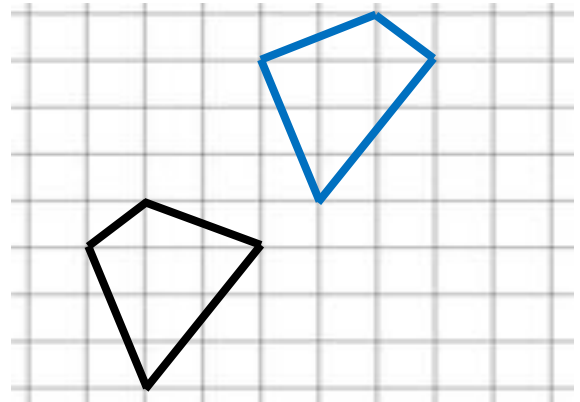

Mistake 2



Explain

Tick the correct box for each example. Explain.

Start position	End position
	
<input type="checkbox"/> The shape has been reflected <input type="checkbox"/> The shape has been translated <input type="checkbox"/> The shape may have been translated or reflected	

Start position	End position
	
<input type="checkbox"/> The shape has been reflected <input type="checkbox"/> The shape has been translated <input type="checkbox"/> The shape may have been translated or reflected	

Explain

Order the circles from smallest to largest:

A circle with a radius of 8cm

A circle with a diameter of 14cm

A circle with a circumference of 25cm

Explain how you know.

Different ways

'In the isosceles triangle, angle A is double angle B'

What are the possible sizes of angles A and B?

Solution 1

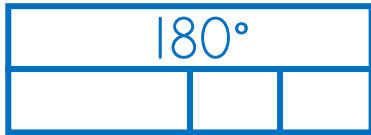
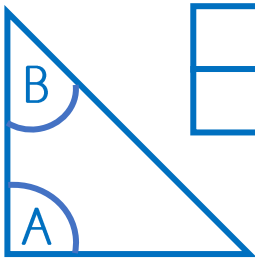

Angle A = Angle B =

Solution 2

Angle A = Angle B =

Explain

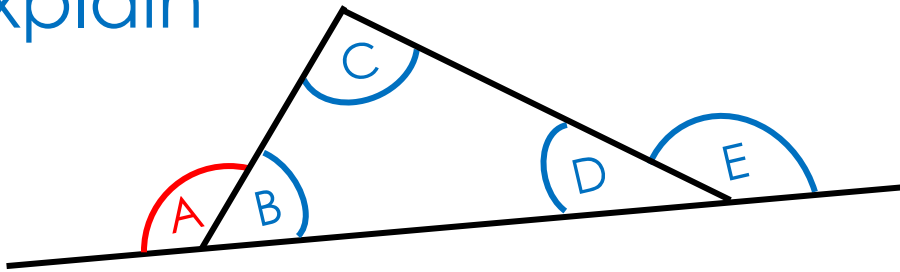

I can work out angle A if I know...

Angles C and D

Angles D and E

Angles C and E

Tick correct option(s).

Explain how you know.

Different ways

The hands of a clock are 90° apart at 3-o'clock and 9-o'clock.

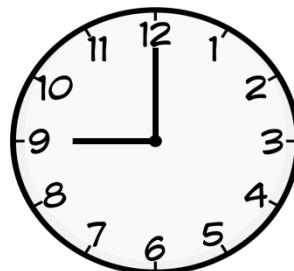
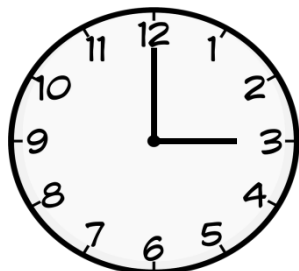

At what time are the hands of a clock 75° apart?

Find two ways.

Explain the mistakes

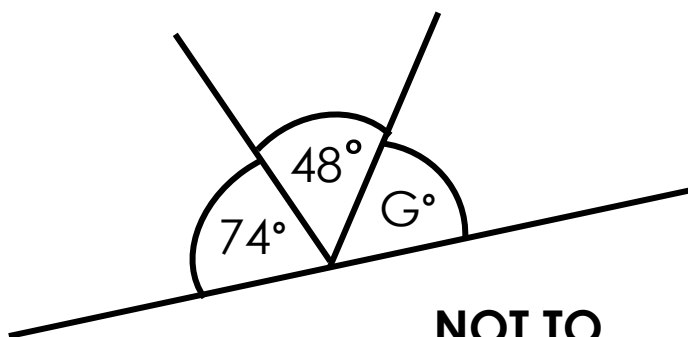

**NOT TO
SCALE**

Calculate the size of angle G

Mistake 1

$$360^\circ - (74^\circ + 48^\circ) = 238^\circ$$

Mistake 2

$$74^\circ + 48^\circ = 122^\circ$$

Mistake 3

$$74^\circ + 48^\circ = 122^\circ$$

$$180^\circ - 122^\circ = 68^\circ$$

Explain the mistakes

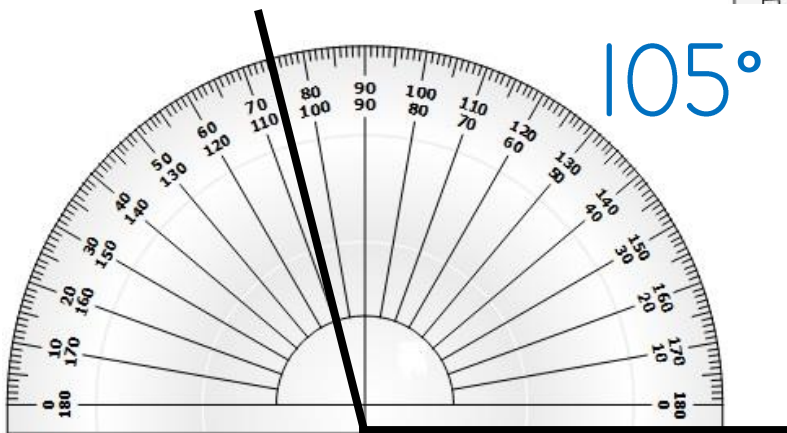
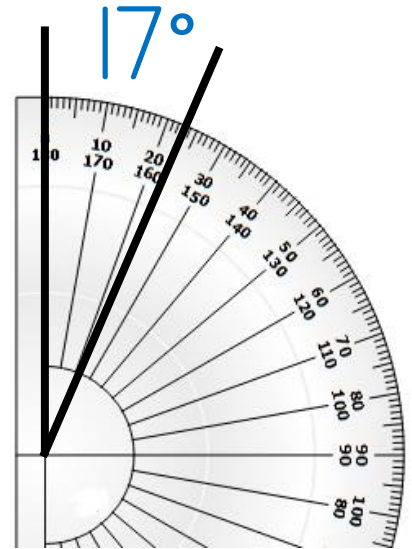
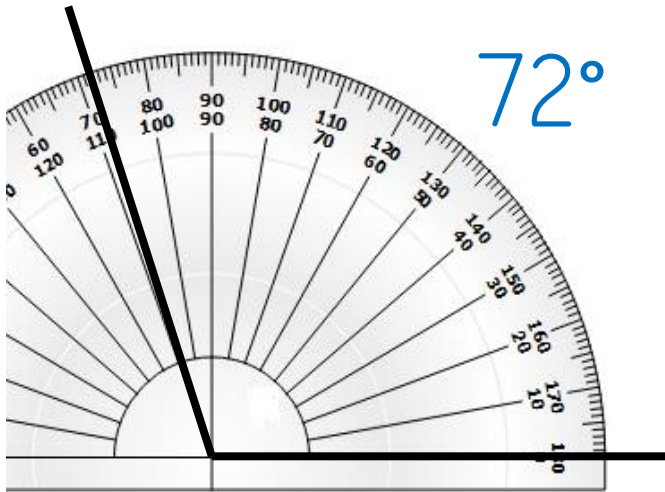

Different ways

Think of possible coordinates for the blue dot.

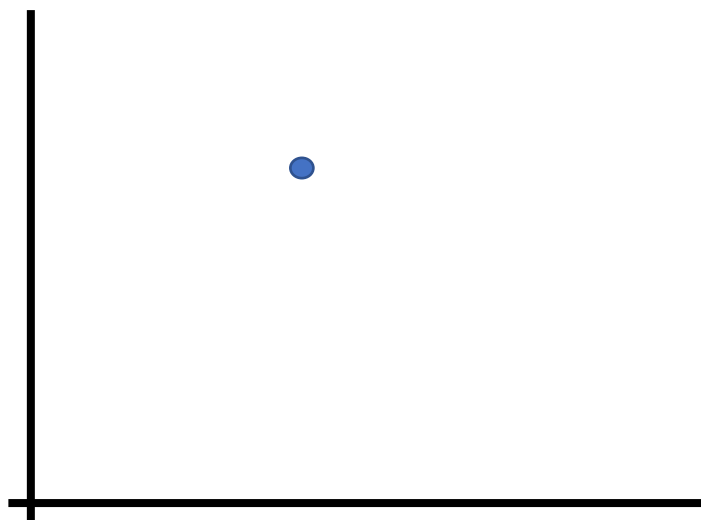

Could the coordinates of the blue dot be:

$(5,8)$

$(20,12)$

$(100,110)$

Explain

Which of the vertices can be calculated?

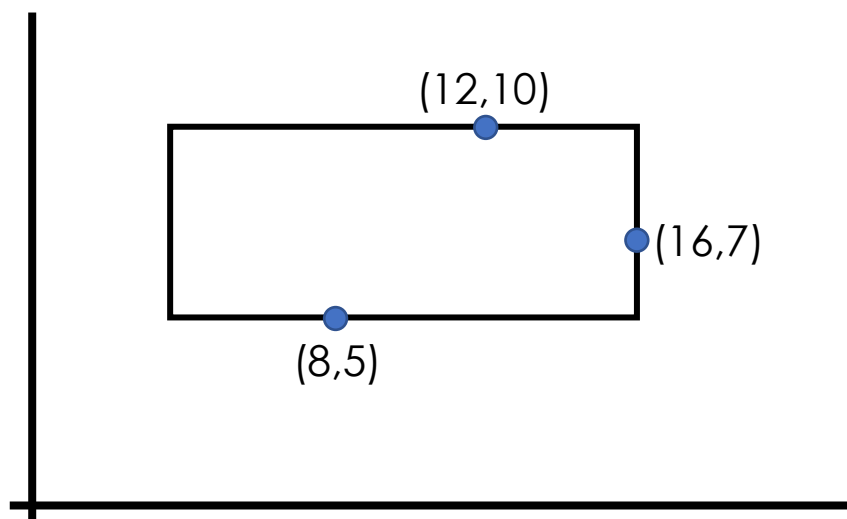

Explain the mistake

Point B is half-way between points A and C.

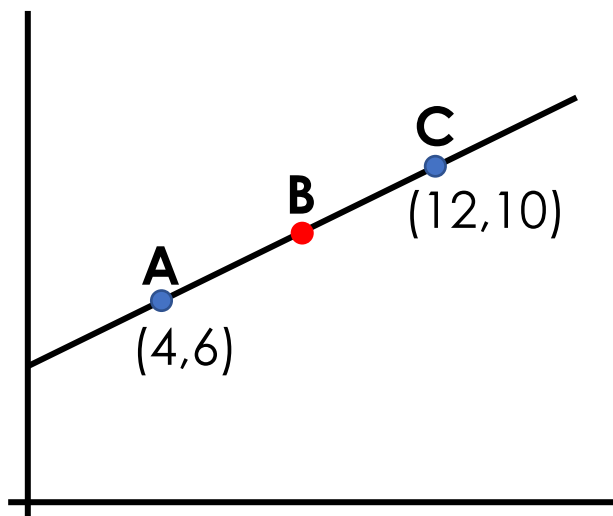

Calculate the coordinates of Point B.

(6.5)



Explain the mistake

Explain the mistake

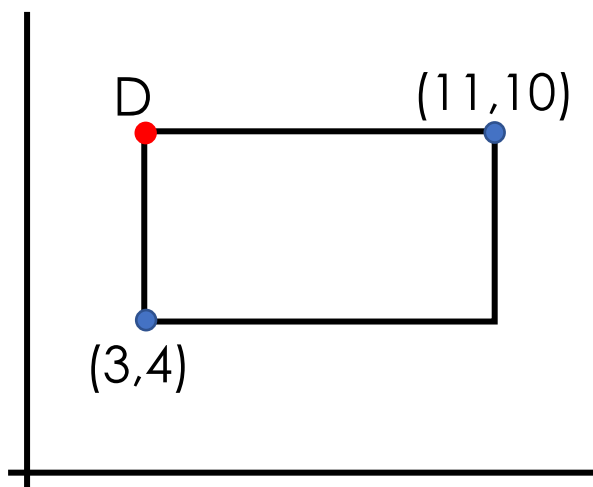

Calculate the coordinates of Point D.

(3.11)



Explain the mistake

Explain

Inside, on the edge or outside the rectangle?

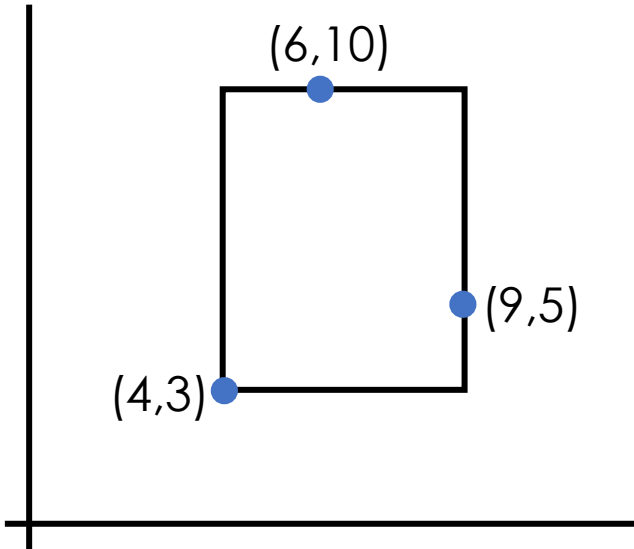

	Inside	Edge	Outside
(4,5)		✓	
(5,9)			
(3,7)			
(9,8)			

Different ways

Identify coordinates that are on these lines:

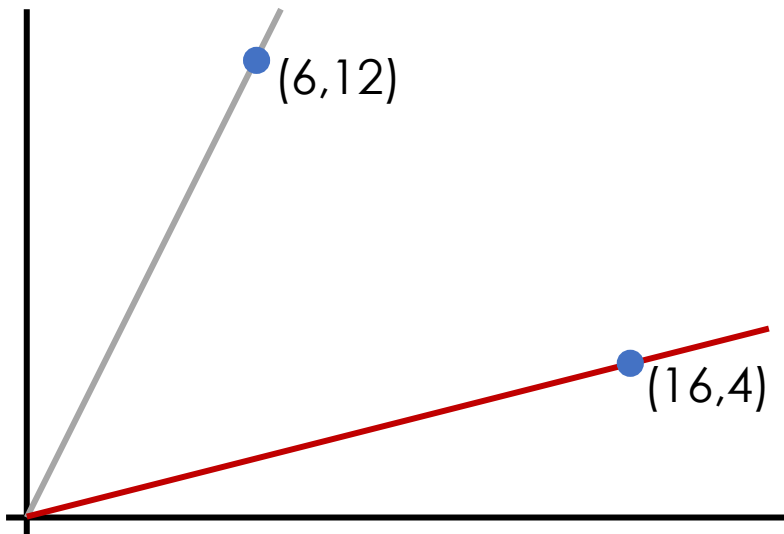

Act the graph

Excitement Shown by Facial Expression

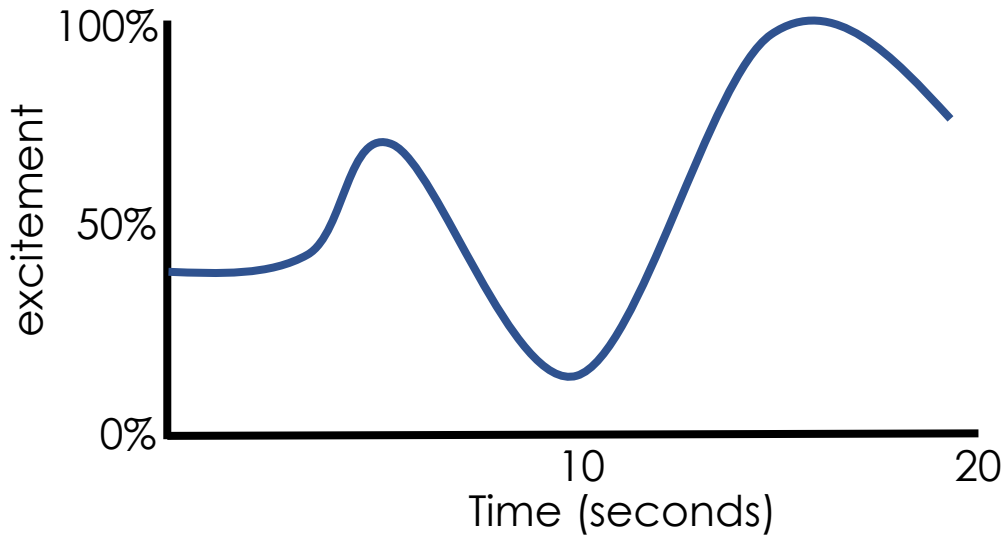

Act the graph

Surprise Shown by Facial Expression

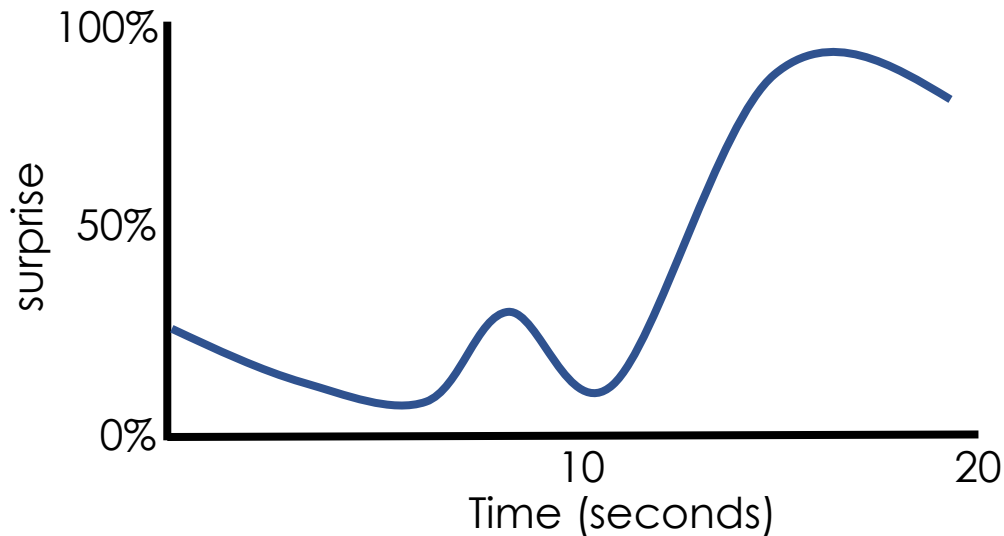

Explain

A school have been collecting data about:

The number of animals seen in the nature area.

How children travel to school.

Attendance for the six KS2 classes each half-term.

In each case, which type of graph should be used to represent the information?

Explain

Marton Vale Primary ran an 'Active Start' project, encouraging children to walk or cycle to school. They wanted to **improve children's fitness** and **reduce traffic congestion** around school.

Mode of Travel to School, February

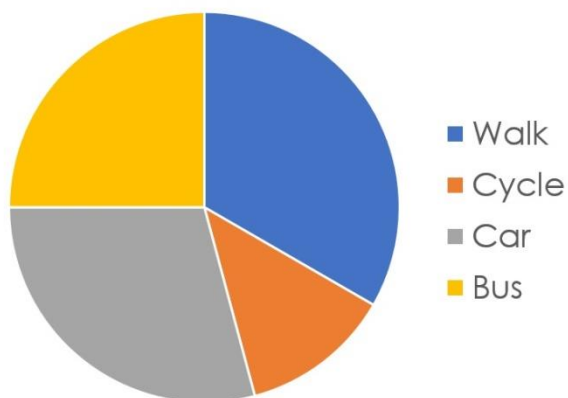

Mode of Travel to School, May

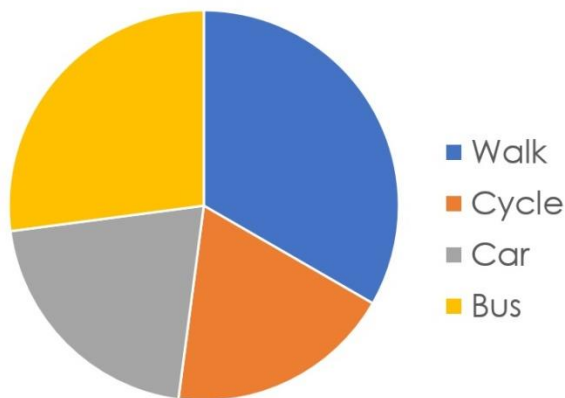

How successful was the 'Active Start' project?

Which answer?

This graph shows the speed of a 400m runner.

What is happening at the point showed by the arrow?

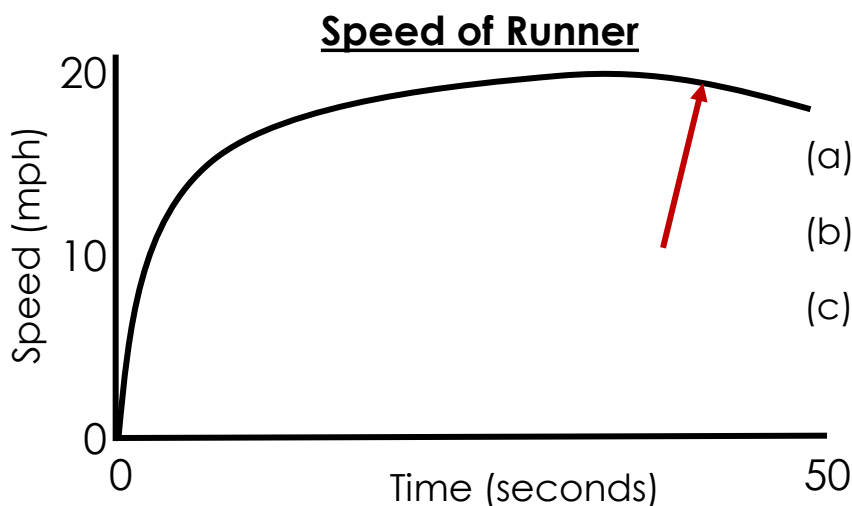

- (a) The runner's fastest speed
- (b) The runner finishes
- (c) The runner slows down

Which answer?

This graph shows the distance travelled by a cyclist.

What is happening at the point showed by the arrow?

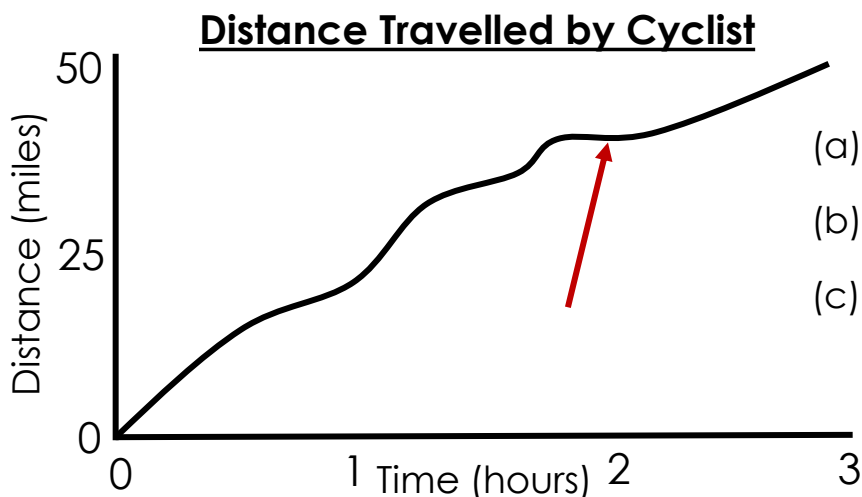

- (a) The cyclist has stopped
- (b) The cyclist is riding slower
- (c) The cyclist is riding at the same speed

Explain

Sam lives in Lancaster. He has a job interview at an office which is a 20-minute walk from Manchester Piccadilly train station. His interview starts at 10:15am.

Here is the train timetable:

Penrith	7:19	7:45	8:11	8:32
Lancaster	7:58	8:24	8:50	9:11
Preston	8:18	8:44	9:10	9:31
Wigan	8:30	8:56	9:22	9:43
Manchester Piccadilly	9:01	9:27	9:53	10:14
Manchester Airport	9:07	9:43	10:09	10:30

At what time does Sam need to arrive at Lancaster train station?

Explain the mistakes

Three different numbers have an average of 8.

What could the numbers be?

Mistake 1

8		
4	3	1

4, 3, 1

Mistake 2

24		
6	9	9

6, 9, 9

Mistake 3

8	8	8
14	7	6

14, 7, 6

Explain

There are four 9-year-old children and a teacher in a classroom.

The average age for the five people in the classroom is 12.

How old is the teacher?

How many ways?

The average of three numbers is 9.

The difference between the smallest and largest number is 5.

What could the numbers be?

Level 1: I can find a way

Level 2: I can find different ways

Level 3: I know how many ways there are

How many ways?

The average of four numbers is 13.

The difference between the smallest and largest number is 7.

What could the numbers be?

Level 1: I can find a way

Level 2: I can find different ways

Level 3: I know how many ways there are

I SEE REASONING – UKS2

Answers

Place value

True or false? True – 2 ten-thousands and 120 hundreds; 3200 tens

Investigate example 1: 109 & 72 or 127 & 90 – difference of 37

Investigate example 2: 1068 & 923 – difference of 145

Explain: D, B, A, C (3 652.5 days in decade; football attendances approximately 40 000; 2 678 400 seconds in January; population of Wales just over 3 million)

Place value – decimals

How many ways example 1: Three ways (two 1s, four 0.1s; one 1, fourteen 0.1s; twenty-four 0.1s)

How many ways example 2: Four ways (three 0.1s, two 0.01s; two 0.1s, twelve 0.01s; one 0.1, twenty-two 0.01s; thirty-two 0.01s)

Place value – negative numbers

Different ways example 1: 5 and -19

Different ways example 2: Subtracting 4 (29, 25, 21...); subtracting 8 (29, 21, 13...); subtracting 16 (29, 13, -3...); subtracting 32 (29, -3, -35...)

Place value – rounding

Which answer? example 1: 404

Which answer? example 2: 2950

I know... so... example 1: 700, 400, 400

I know... so... example 2: 2050, 3170, 20

Explore example 1: children may make the hidden number 100, making a largest value for E = 449. If the hidden number was 400 E could be 599.

I SEE REASONING – UKS2

Answers

Place value – rounding (continued)

Explore example 2: If $A = 450$ and $B = 354$, the difference is 96

How many ways? 3 ways (145 & 152, 146 & 153, 147 & 154)

Addition and subtraction

Investigate example 1: Example $76+53=129$ (note: the digit 1 must be the hundreds value in the 3-digit number)

Investigate example 2: Example $71-23=48$

How many ways? 3 ways ($17=8+4+3+2$; $17=6+5+4+2$; $27=9+8+6+4$)

Explain: 42, 48, 54

Multiplication

Matching number sentences: Example $35+14+7=7\times 8$; $160-16=16\times 9$;
 $80+16=12\times 8$

True or false? example 1: 15×15 one more than 16×14 , four more than 17×13 , nine more than 18×12 (note continuing pattern of square numbers, can be investigated further)

How many ways? example 1: 3 ways ($27\times 3=81$; $19\times 3=57$; $29\times 3=87$)

How many ways? example 2: 3 ways ($67\times 3=201$; $87\times 3=261$; $93\times 7=651$)

Missing digits: $783\times 9=7047$; $573\times 6=3438$; $253\times 37=9361$; $815\times 64=52160$

Explain: 28 as it has more factors (1, 2, 4, 7, 14, 28) than 34 (1, 2, 17, 34)

Explore: 2 is the only number in the middle (the only even prime)

True or false? False: when the square root of an odd square number is prime it has 3 factors (e.g. 49). Otherwise there are more than 3 factors (e.g. 81 has factors 1, 3, 9, 27, 81).

I SEE REASONING – UKS2

Answers

Division

Form of answer example 1: 7 hours 45 minutes

Form of answer example 2: sunflower 13.67cm (2 d.p.); 13 teams; masterpiece 13 hours 40 minutes

True or false? False, e.g. 27

How many ways? example 1: 6 ways ($60 \div 60 = 12 \div 12$; $60 \div 30 = 12 \div 6$; $60 \div 20 = 12 \div 4$; $60 \div 15 = 12 \div 3$; $60 \div 10 = 12 \div 2$; $60 \div 5 = 12 \div 1$)

How many ways? example 2: 2 ways ($30 \div 7 = 4 \text{ r } 2$; $65 \div 7 = 9 \text{ r } 2$)

How many ways? example 3: 2 ways ($30 \div 4 = 7 \frac{1}{2}$; $38 \div 4 = 9 \frac{1}{2}$)

Fractions

Explain example 1: $\frac{1}{2}$ green, $\frac{1}{4}$ blue, $\frac{1}{8}$ yellow, $\frac{1}{8}$ red

Explain example 2: $\frac{3}{16}$

Different ways example 1: assuming $\frac{3}{8}$ is in the middle, possible combinations include $\frac{2}{8}$ & $\frac{4}{8}$; $\frac{1}{4}$ & $\frac{1}{2}$; $\frac{1}{8}$ & $\frac{5}{8}$; 0 & $\frac{3}{4}$

How many ways? example 1: 2 ways ($\frac{6}{8} > \frac{3}{5}$; $\frac{5}{8} > \frac{3}{6}$)

Explore: $\frac{3}{5}$ in centre; $\frac{4}{10}$ and $\frac{3}{6}$ in right-side section; $\frac{7}{8}$ in left-side section.

Different ways example 3: Section A no fractions; section B two fractions ($\frac{2}{5}$ and $\frac{2}{6}$); section C three fractions ($\frac{2}{3}$, $\frac{3}{5}$ and $\frac{4}{6}$); section D two fractions ($\frac{4}{5}$ and $\frac{5}{6}$).

How many ways? example 2: two ways ($\frac{4}{6}$ and $\frac{5}{8}$)

I SEE REASONING – UKS2

Answers

Fractions + - × ÷

How many ways? example 1: 6 ways ($\frac{1}{8} + \frac{1}{8} = \frac{1}{4}$; $\frac{2}{8} + \frac{1}{4} = \frac{2}{4}$; $\frac{3}{8} + \frac{1}{8} = \frac{2}{4}$;

$$\frac{2}{8} + \frac{1}{2} = \frac{3}{4}; \frac{4}{8} + \frac{1}{4} = \frac{3}{4}; \frac{5}{8} + \frac{1}{8} = \frac{3}{4}$$

How many ways? example 2: 6 ways ($\frac{1}{5} + \frac{2}{4} = \frac{14}{20}$; $\frac{1}{5} + \frac{2}{5} = \frac{12}{20}$; $\frac{1}{5} + \frac{2}{8} = \frac{9}{20}$;

$$\frac{1}{5} + \frac{2}{10} = \frac{8}{20}; \frac{1}{5} + \frac{2}{20} = \frac{6}{20}; \frac{1}{5} + \frac{2}{40} = \frac{5}{20}$$

How many ways? example 3: 4 ways, two using proper fractions and two using improper fractions ($\frac{1}{4} \times 15 = 3\frac{3}{4}$; $\frac{3}{4} \times 5 = 3\frac{3}{4}$; $\frac{5}{4} \times 3 = 3\frac{3}{4}$;

$$\frac{15}{4} \times 1 = 3\frac{3}{4}$$

How many ways? example 4: 4 ways ($\frac{1}{4} \times \frac{1}{2} = \frac{1}{8}$; $\frac{2}{4} \times \frac{1}{4} = \frac{1}{8}$; $\frac{2}{4} \times \frac{1}{2} = \frac{2}{8}$;

$$\frac{3}{4} \times \frac{1}{2} = \frac{3}{8}$$

Ratio and proportion

Which picture? example 1: brown and orange images (45 split into 3 equal parts, two of those parts girls and one boys)

Which picture? example 2: Jen's method, recognising 300 as the total number of right-handed children.

Algebra

Which one? $\pounds 4h + \pounds 6 = \text{cost to hire wetsuit}$; $\pounds 6h + \pounds 4 = \text{cost to hire surfboard}$

Explain example 1: n can be any value up to a maximum of 7

Explain example 2: $25 < 20 + s$ infinite number of values; $5s - 2 = 18$ one possible value; $5s + 2 = t$ infinite number of values

I SEE REASONING – UKS2

Answers

Measures

Explore example 1: pounds in centre; miles and pints in left; grams in right; metres on outside.

Explore example 2: metric measures (left); measures of volume (right)

Order: 18000 seconds = 5 hours, 6 hours, 400 minutes = $6\frac{2}{3}$ hours,

$\frac{1}{3}$ of day = 8 hours

Measures – volume

Estimate example 1: first shape could be length = 8cm, width = 3cm, height = 3cm; second shape could be length = 6cm, width = 3cm, height = 4cm

Estimate example 2: volume of cube = 64cm^3 ; volume of cuboid 108cm^3 , estimate to be slightly more than half full.

Measures – area and perimeter

Estimate: based on sides of 8cm and 3cm, perimeter = 22cm^2

Explain example 1: join long sides of rectangle with no overlap

Explain example 2: 25cm^2

Draw: Example smaller area and larger perimeter $10\text{cm} \times 2\text{cm}$ rectangle. Example same perimeter and larger area $6\text{cm} \times 5\text{cm}$ rectangle.

Different ways example 1: area = 192.5cm^2

Different ways example 2: area = 36cm^2

I SEE REASONING – UKS2

Answers

Geometry – shape

Explore example 1: Example headings - all sides same length (left); at least one acute angle (right).

Explore example 2: Example headings – top heading ‘does the shape have a reflex angle?’, left heading ‘does the shape have any acute angles?’, right heading ‘does the shape have two pairs of parallel lines?’

Fill in the gaps example 1: row 1 – faces; row 2 – triangular pyramid; row 3 – 18

Fill in the gaps example 2: row 1 – vertices; row 2 – 6; row 3 – triangular prism; row 4 – 5 faces, 5 vertices

Different ways:

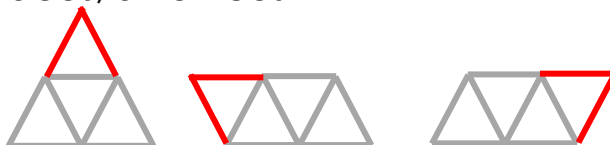

Is it correct?

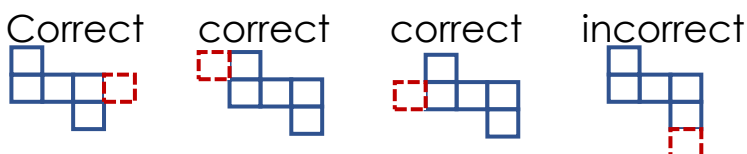

Explain example 1: Left – may have been translated or reflected. Right – reflected.

Explain example 2: smallest is circle circumference of 25cm; then circle with a diameter of 14cm; largest is circle with a radius of 8cm.

Geometry – angle

Different ways example 1: Solution 1 – angle A=90°, angle B=45° (third angle is 45°). Solution 2 – angle A=72°, Angle B=36° (third angle is 72°)

Explain: Tick boxes for angles C and D & angles C and E

Different ways example 2: 8:30 or 3:30

I SEE REASONING – UKS2

Answers

Geometry – coordinates

Explain example 1: top-right and bottom-right

Explain example 2: (5,9) inside; (3,7) outside; (9,8) edge

Different ways: Examples grey line (4,8),(3,6); examples red line (4,1),(8,2)

Statistics

Explain example 1: Consider how bar graph places greater emphasis on quantities (possibly relevant to animals in nature area), whereas pie chart emphasises relative quantities (may suit mode of travel). Line graph can show trends over time, may be used for attendance.

Explain example 2: The proportion walking and getting the bus remain similar. The main change is a reduction in those travelling by car (congestion) and in increase in children using their bike (fitness).

Which answer example 1: The runner slows down

Which answer example 2: The cyclist has stopped

Explain example 3: Getting the 8:50am train from Lancaster means Sam is due to arrive for his interview at 10:13am, only 2 minutes before it starts. It may be advisable, therefore, for Sam to get the 8:24am train. He should arrive at Lancaster station before this departure time.

Statistics – average

Explain the mistakes: Mistake 1 – total of 8; mistake 2 – not three different numbers; mistake 3 – bottom row numbers don't total 24.

Explain: 24 years-old

How many ways? example 1: 2 ways (6, 10, 11 & 7, 8, 12)

How many ways? example 2: 8 ways (8, 14, 15, 15; 9, 11, 16, 16; 9, 12, 15, 16; 9, 13, 14, 16; 10, 10, 15, 17; 10, 11, 14, 17; 10, 12, 13, 17; 11, 11, 12, 18)